



UPPSALA
UNIVERSITET

Hydrogen storage materials

Max Wolff
Department for Physics and Astronomy
Uppsala University

Hydrogen economy

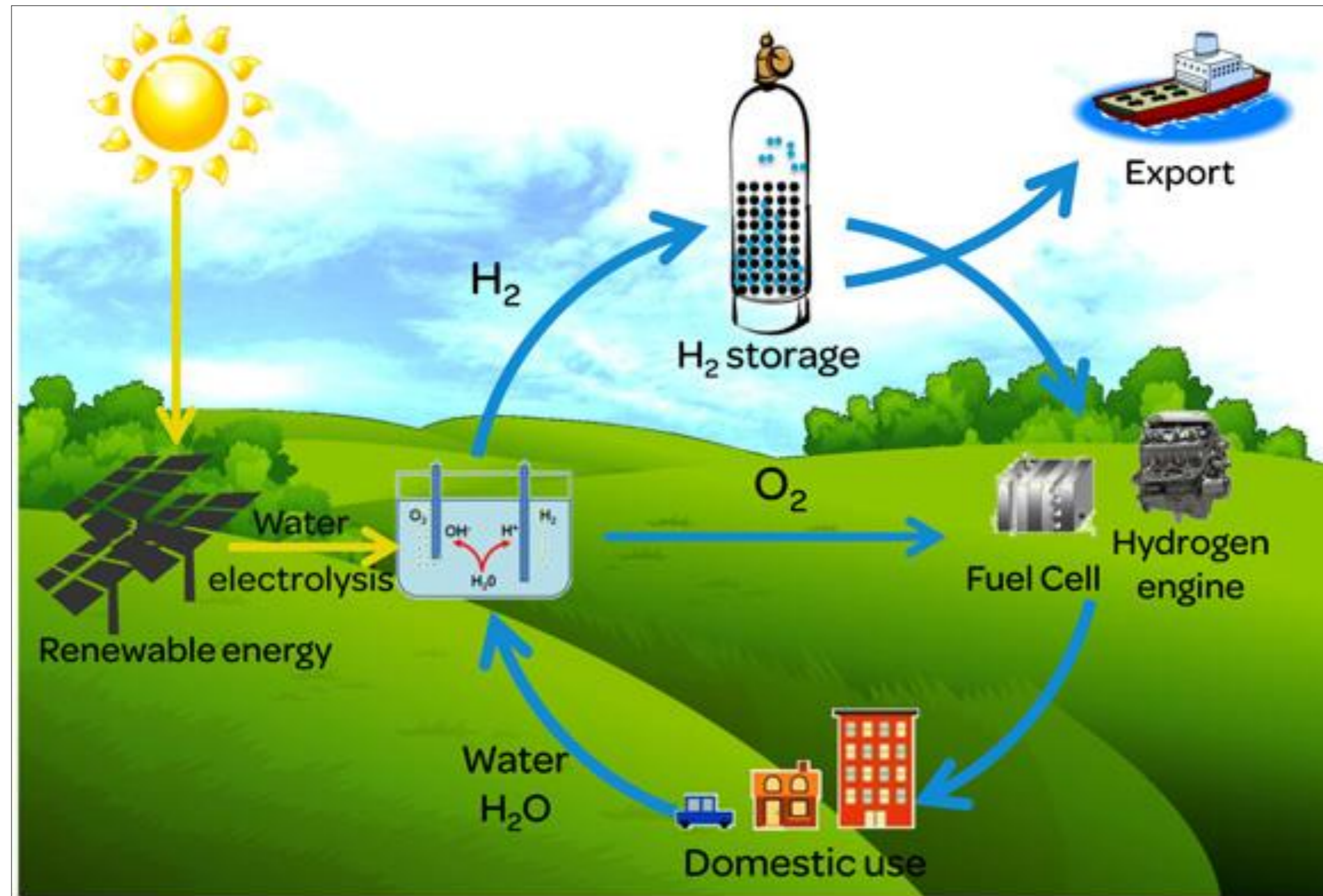

Hydrogen economy

Means to store energy from renewables

Mobile applications

Cars, Trucks, Forklifts, Ships, Cell Phones

Stationary applications

Energy buffer in power plants
Home storage

How much can you stretch a metallic glass with hydrogen in one dimension?

Does the storage capacity of a nano material depend on its surroundings?

Hydrogen economy



Possibilities to tune properties towards application?

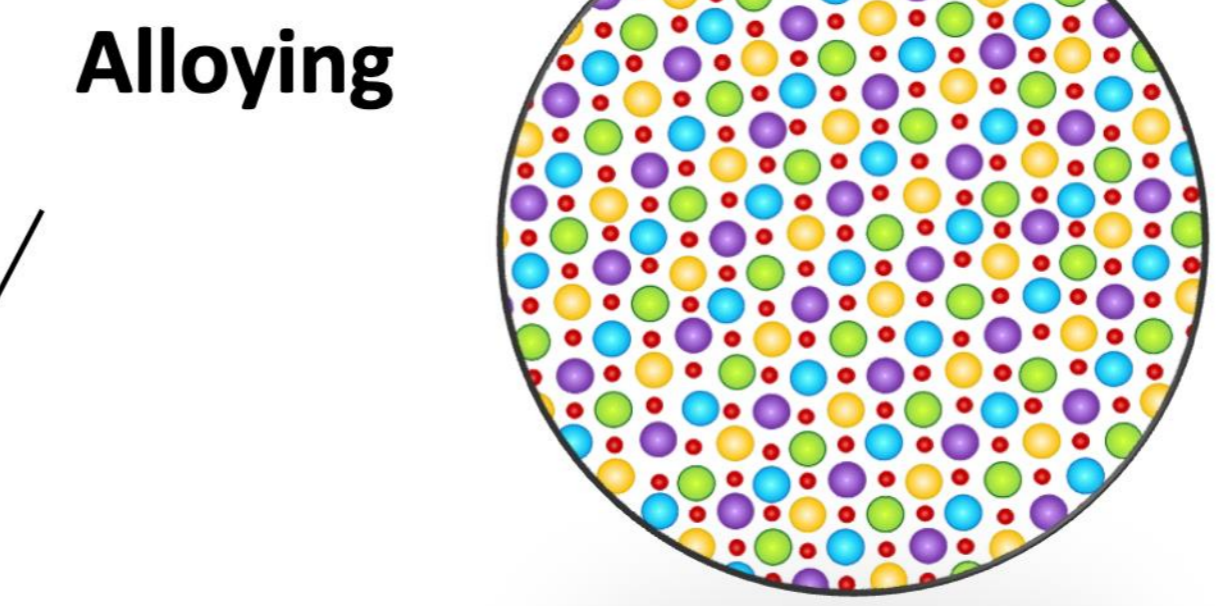
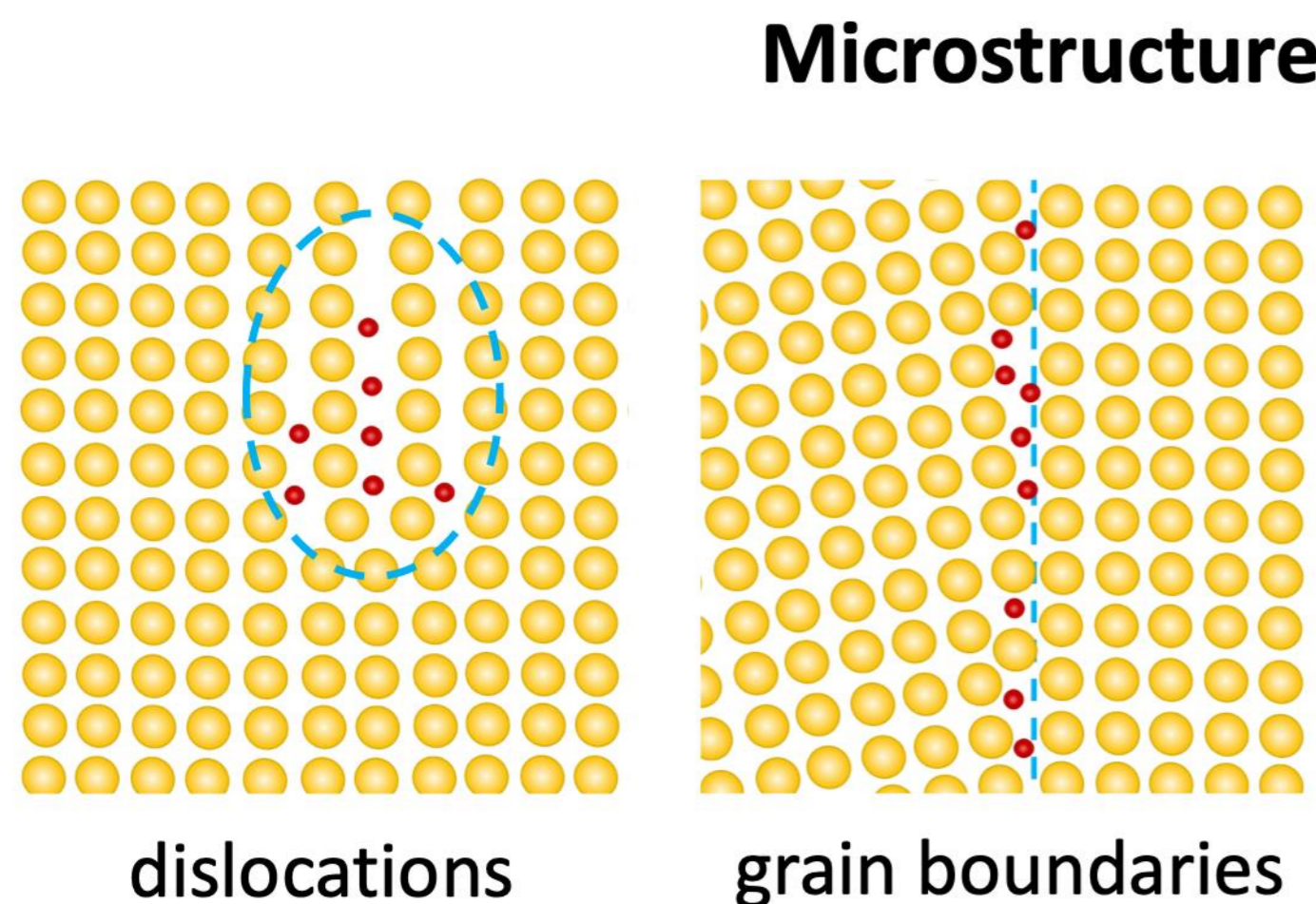
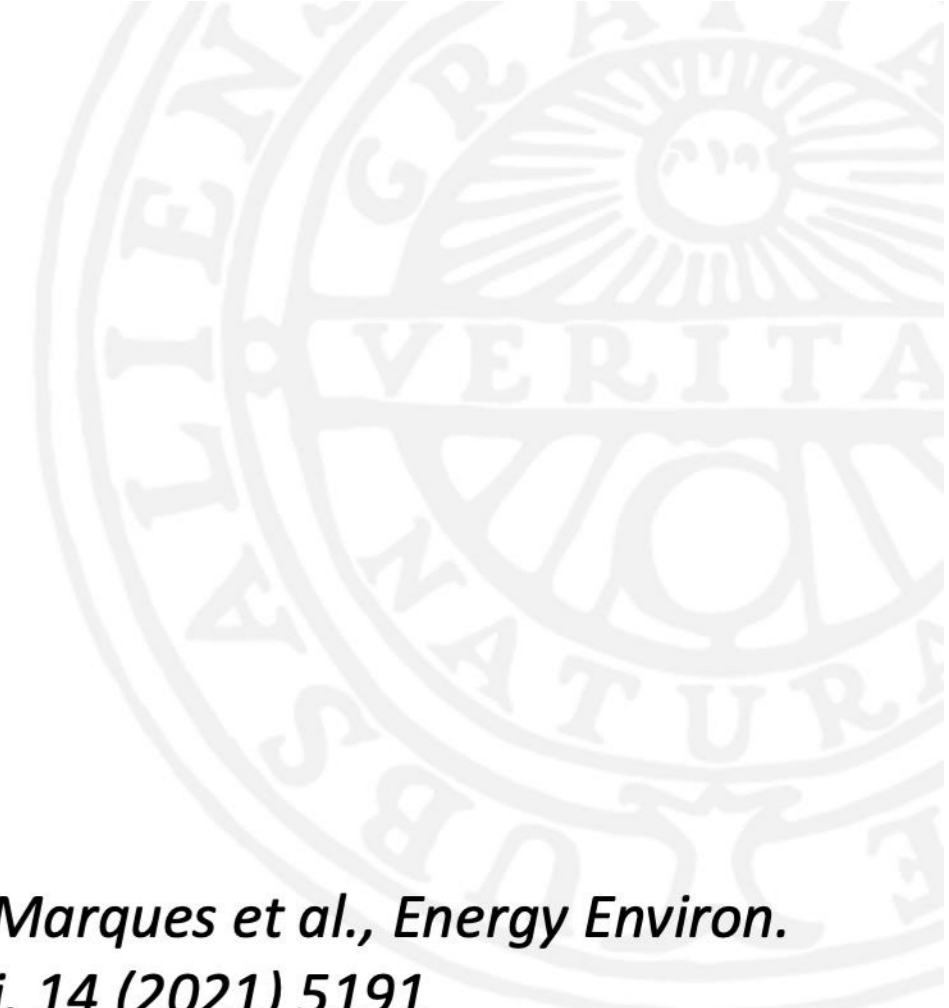

F. Marques et al., Energy Environ. Sci. 14 (2021) 5191

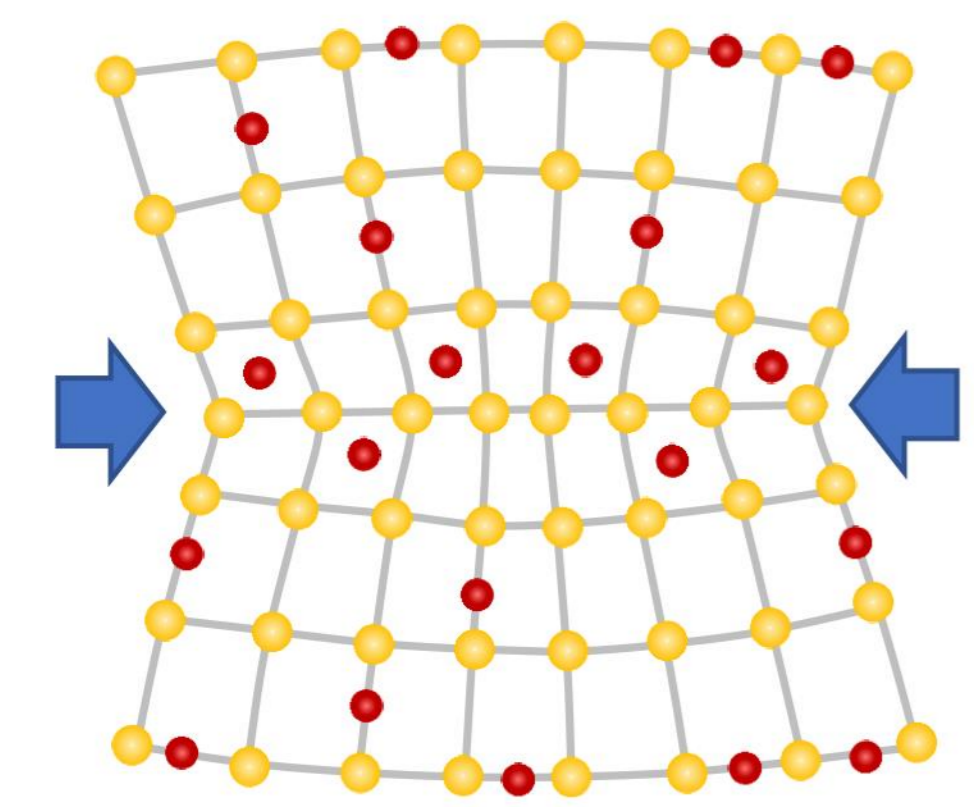
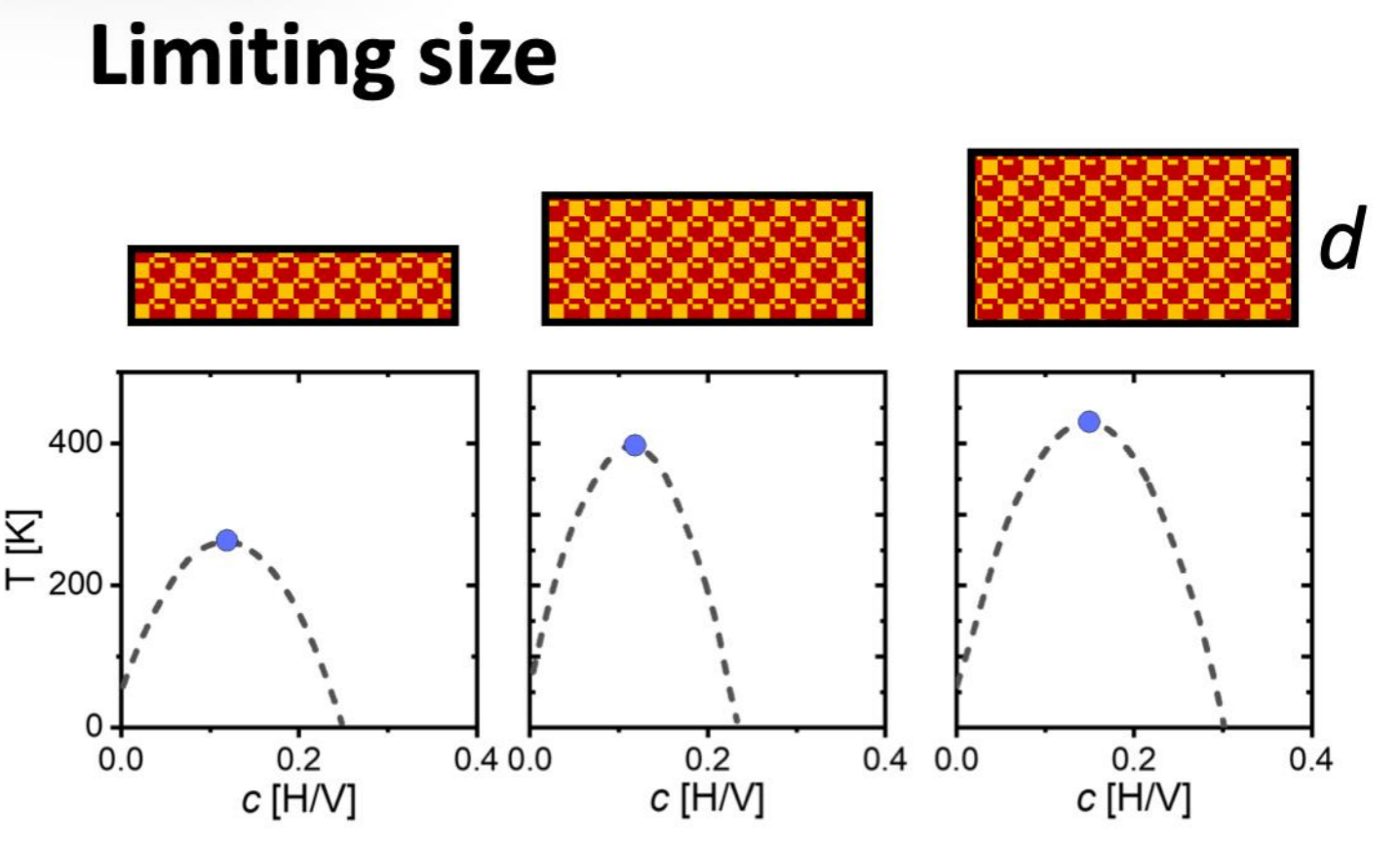
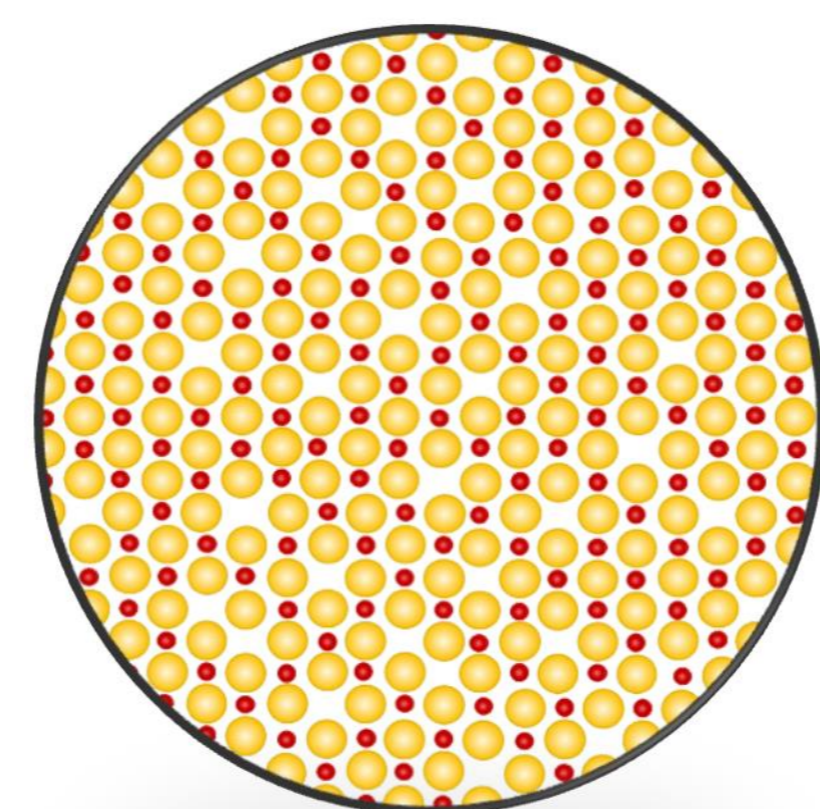

A. Baldi et al., PRL 102 (2009) 226102
R. Johansson et al., Sci. Rep 5 (2015) 10301

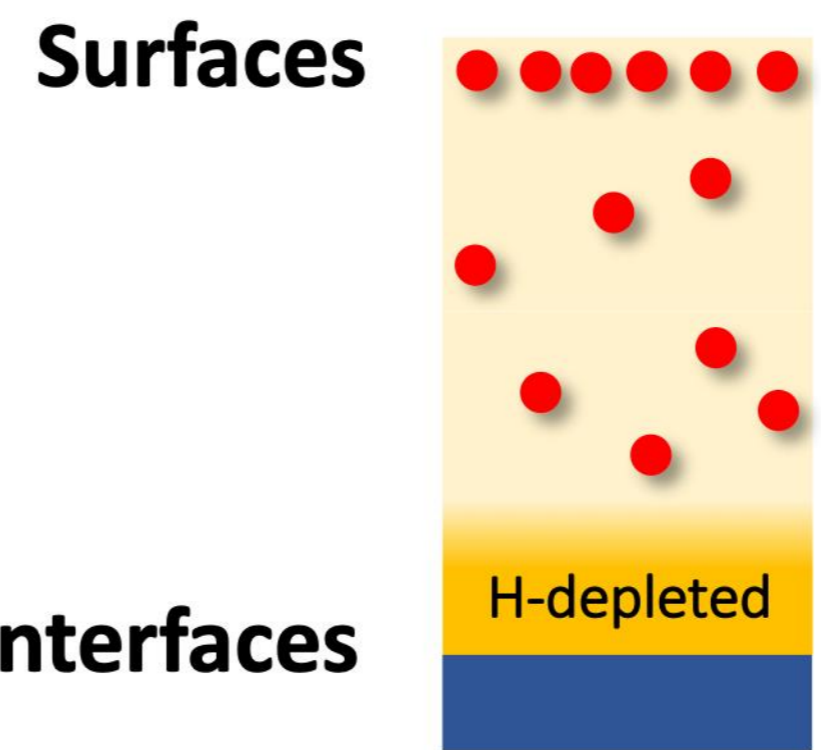

R. Griessen et al., Nat. Mater 15 (2016) 311
G. Andersson et al., PRB 55 (1997) 1774



Super lattices

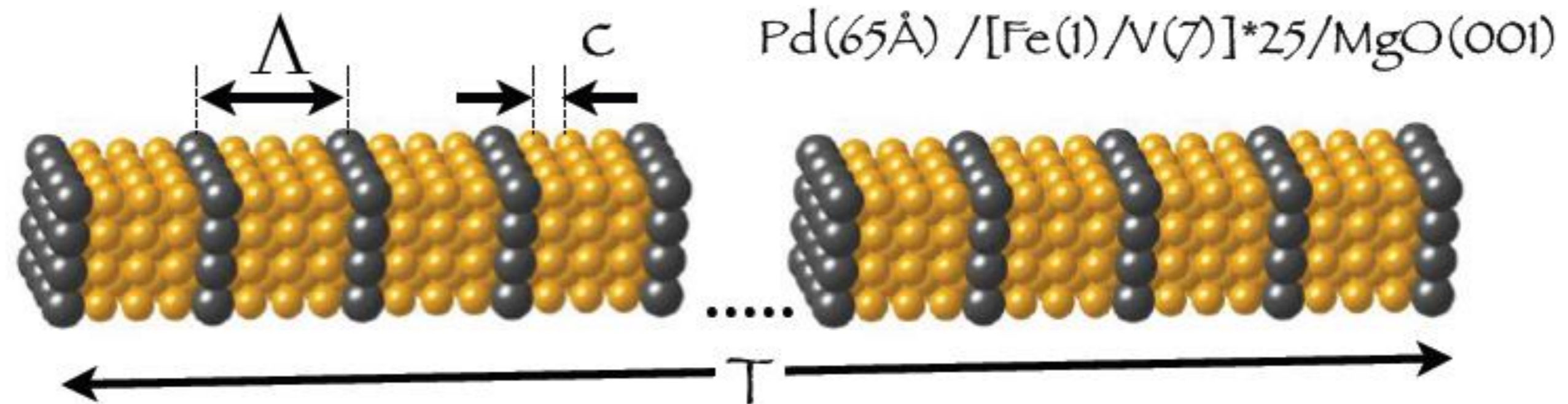
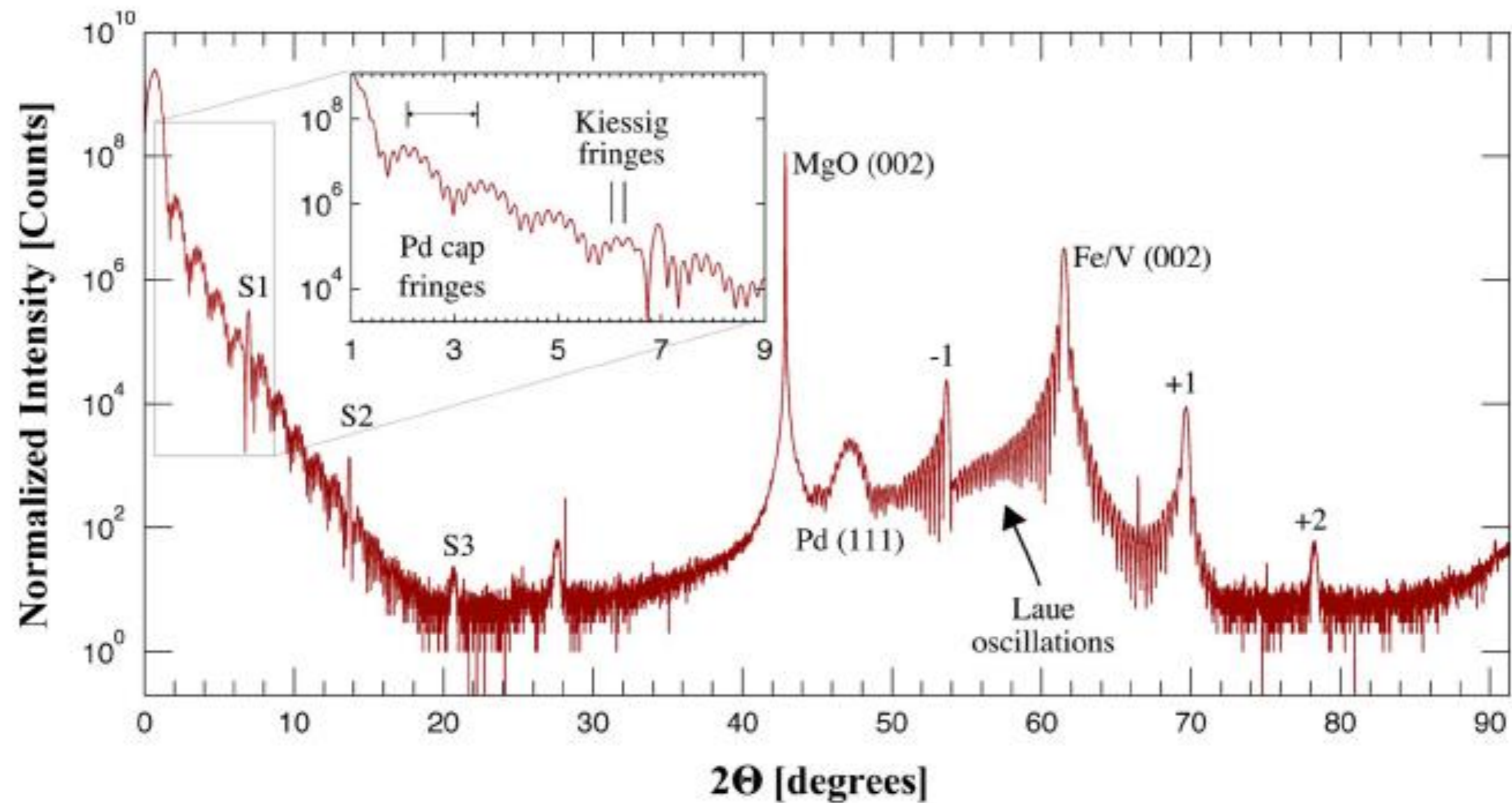

Single crystalline multilayers

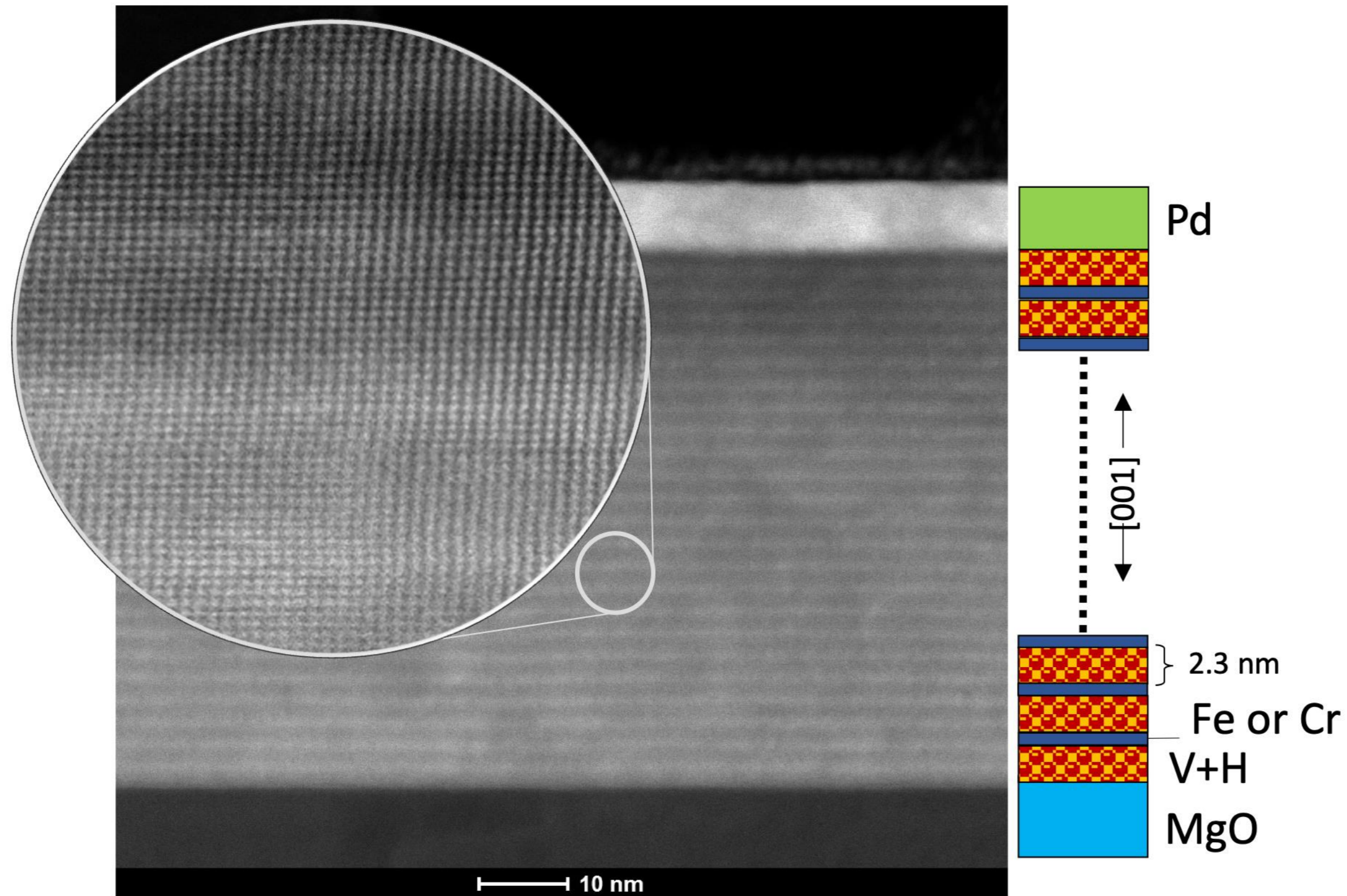

MgO substrate top view:

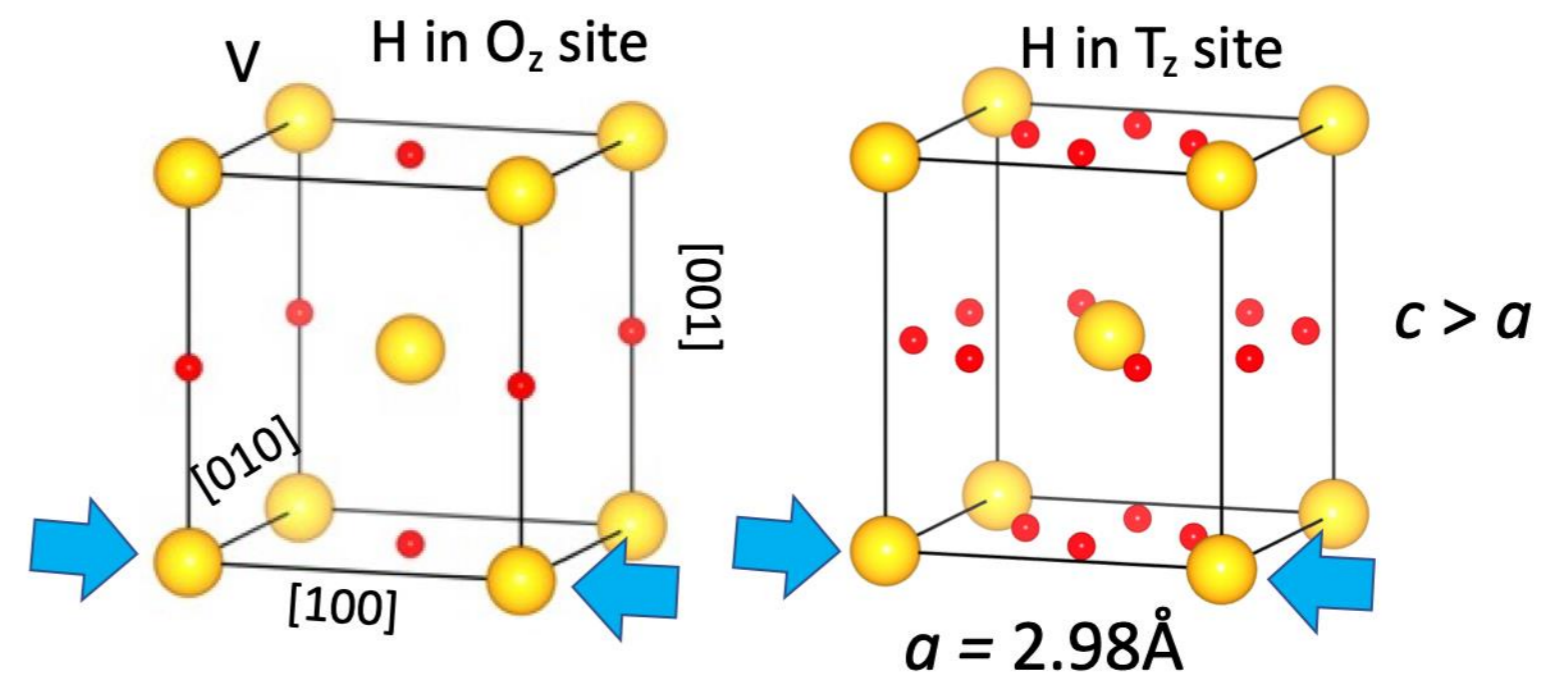
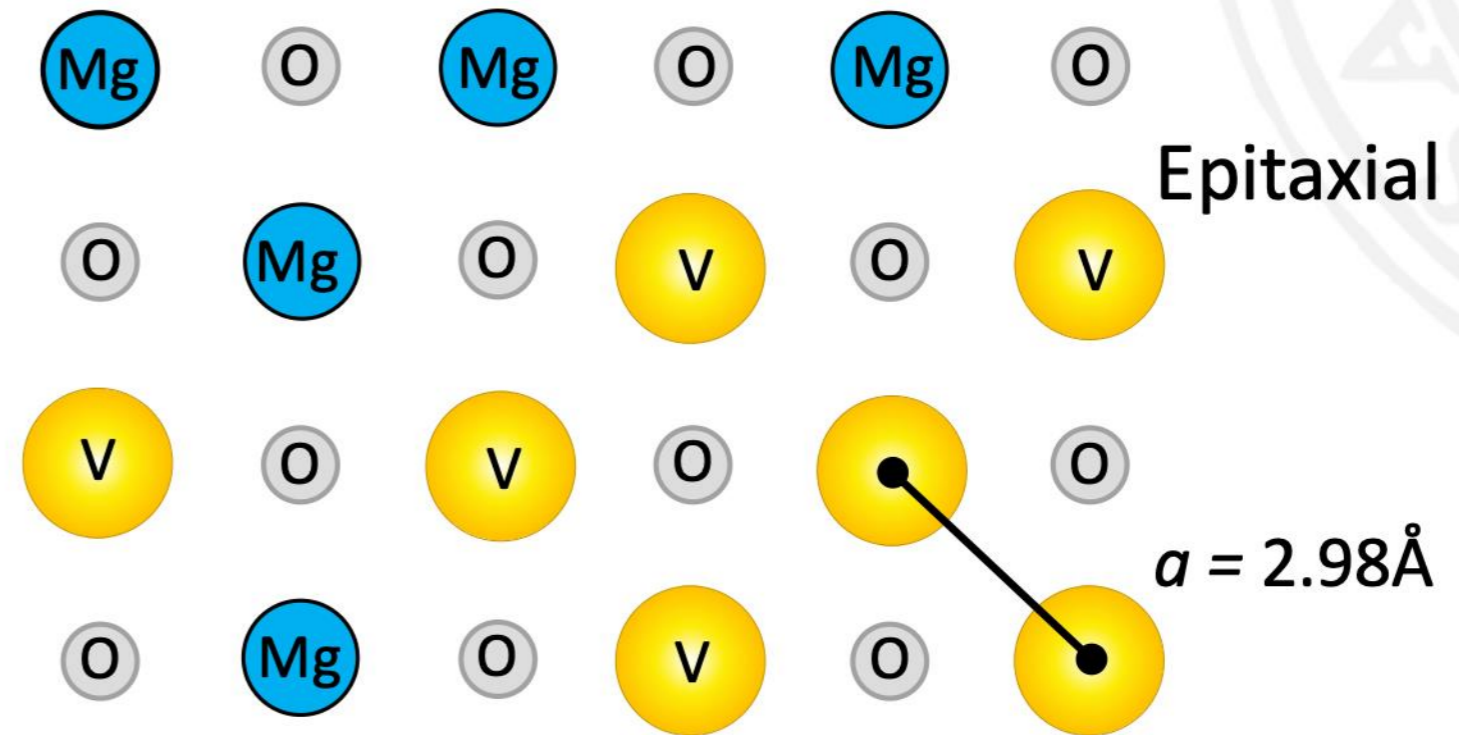

biaxially confined

- strain
- finite size
- interfaces

Vanadium phase diagram

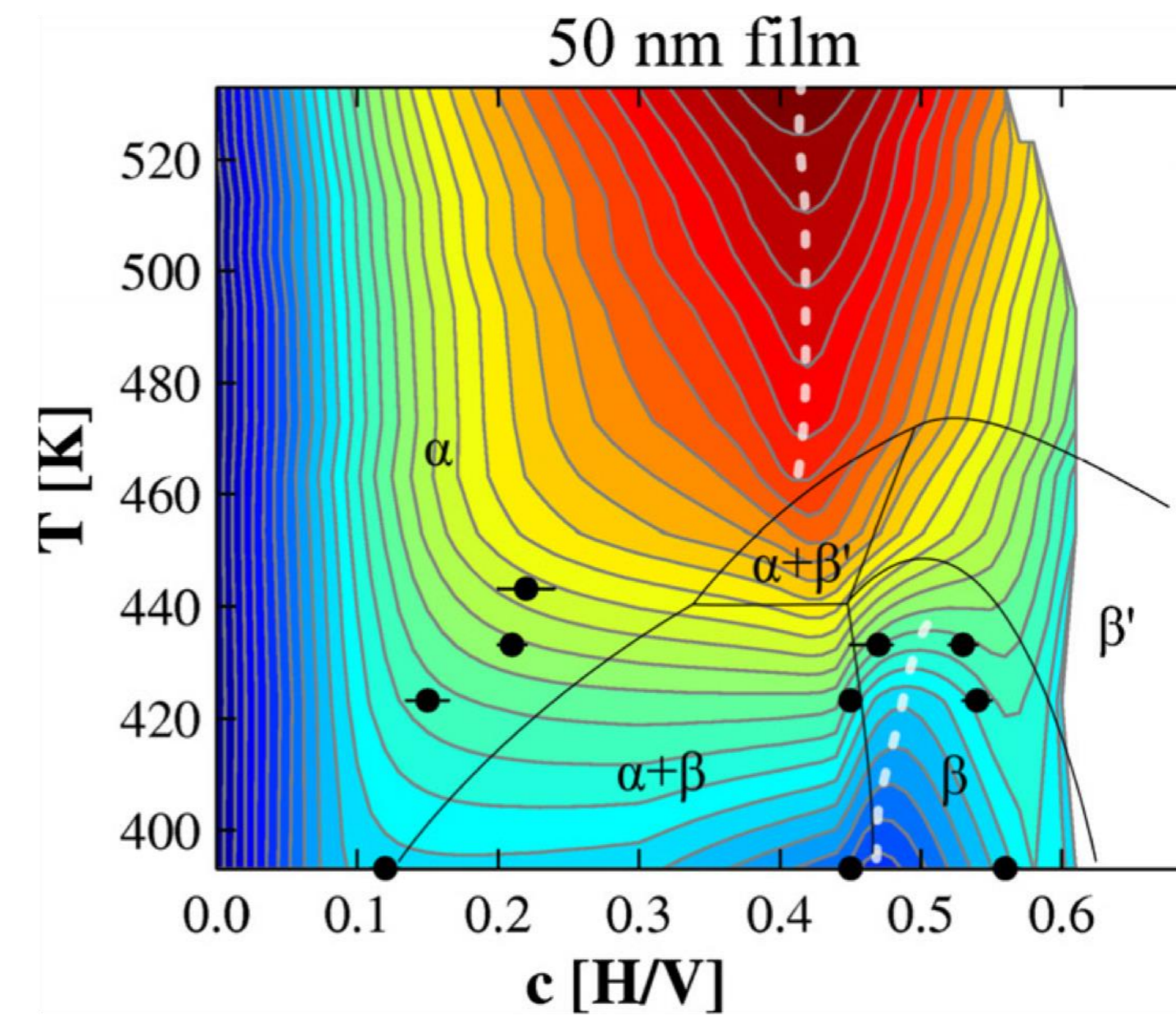
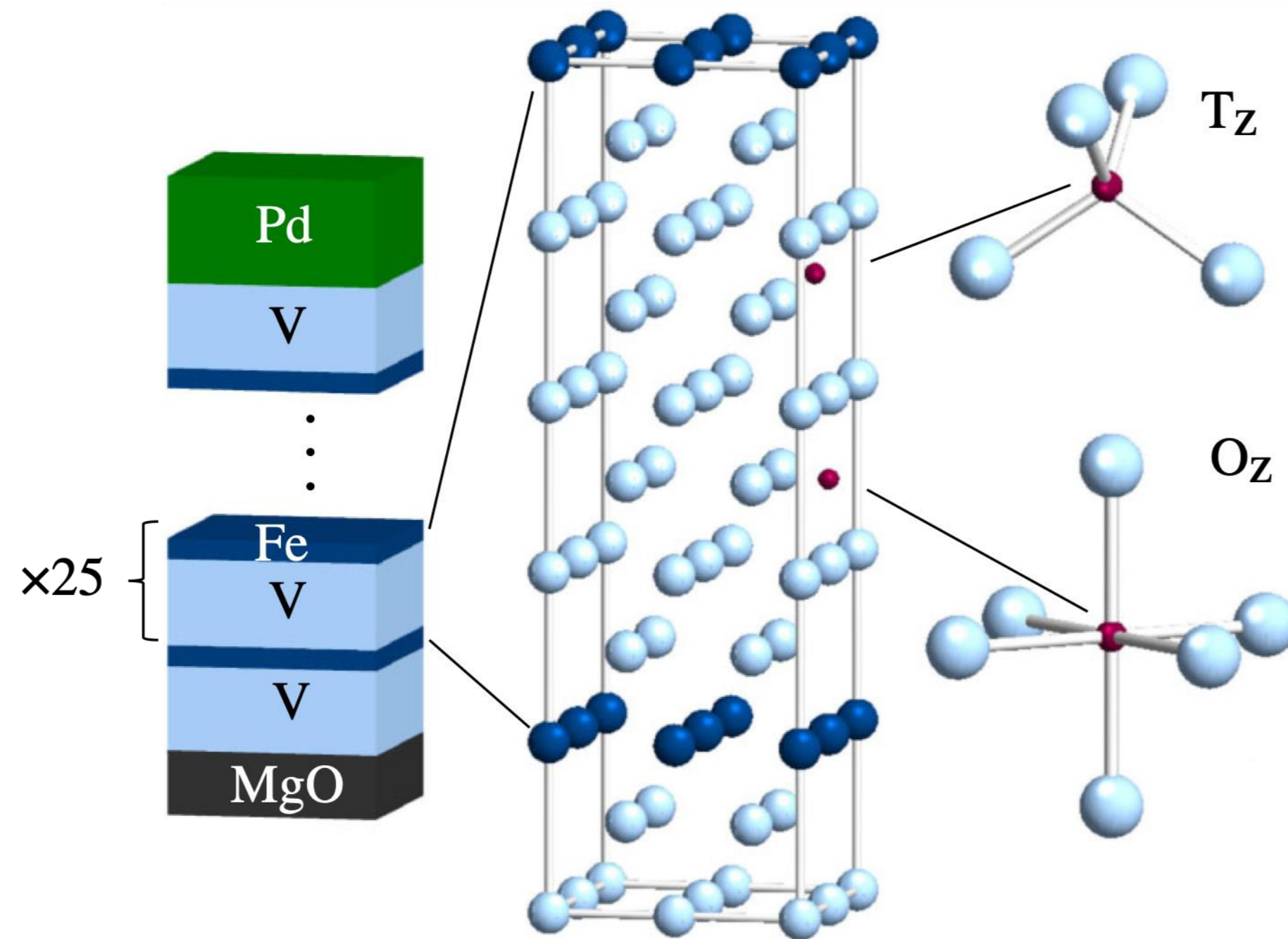

Lattice parameter:

$$d_{\text{Fe}} = 2.87 \text{ \AA}$$

$$d_{\text{V}} = 3.03 \text{ \AA}$$

Film clamped to the substrate
 Expansion only possible out of plane
 V tetragonal distorted
O_z sites preferably occupied

Resistivity and optical transmission

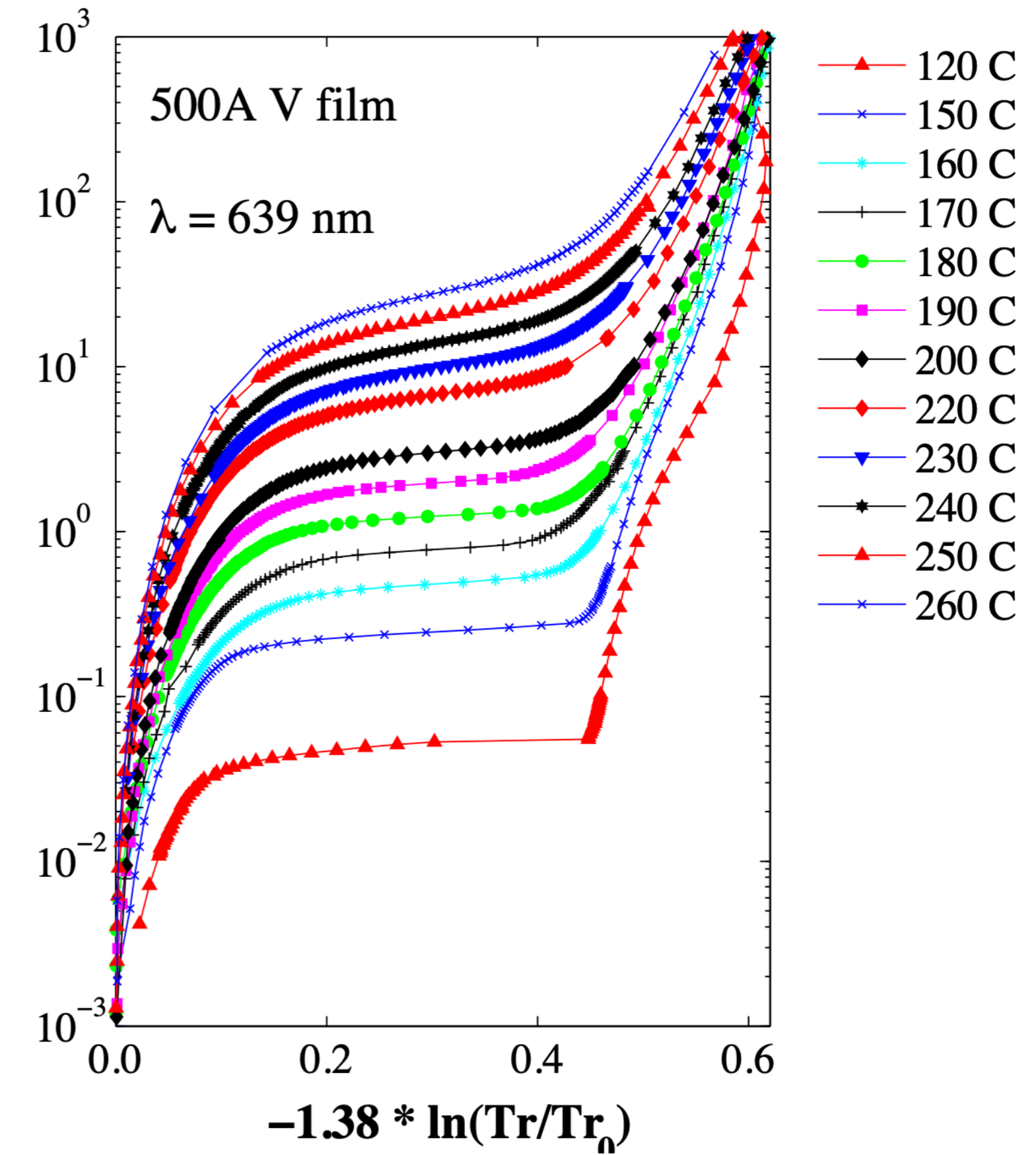
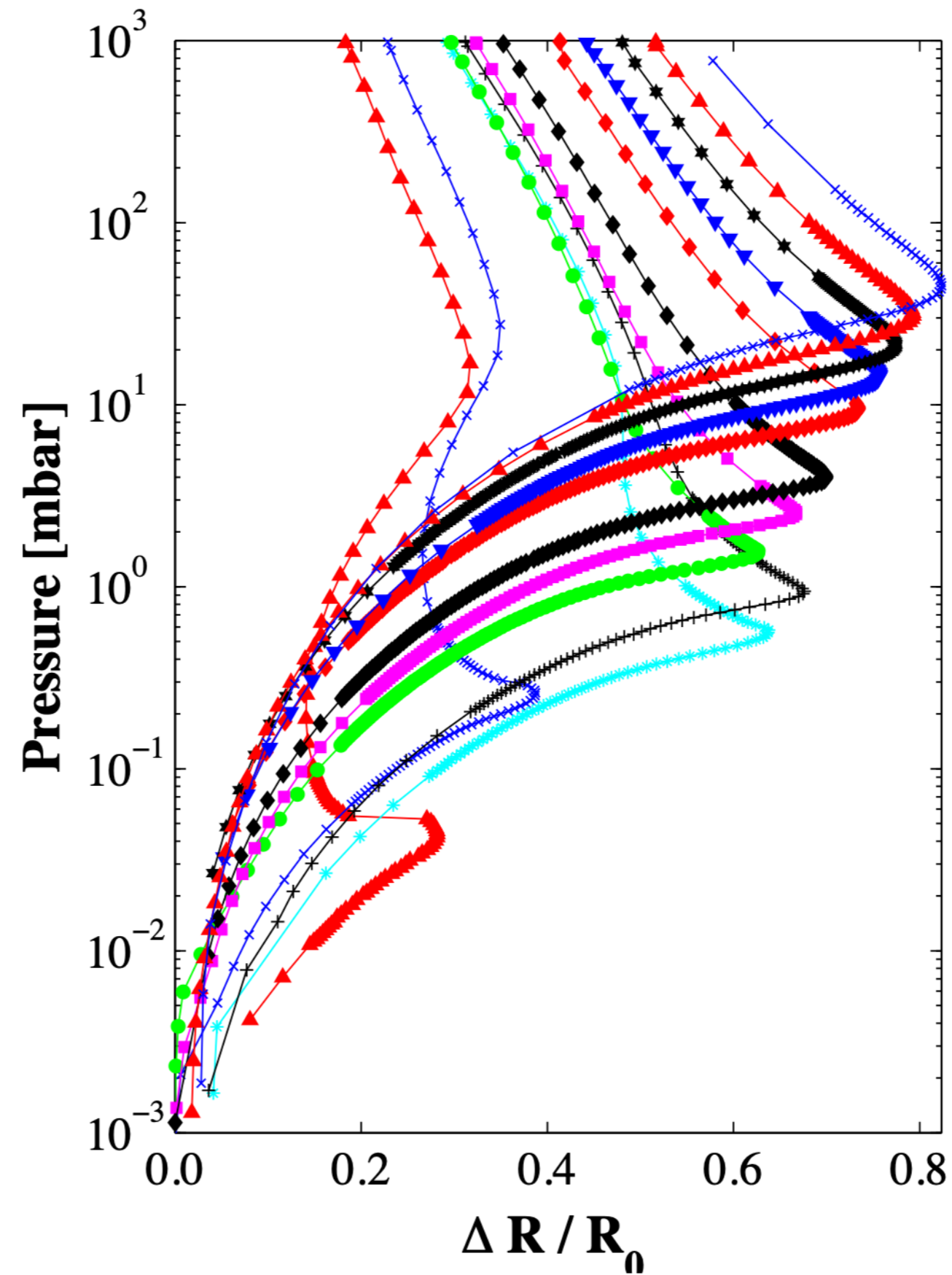
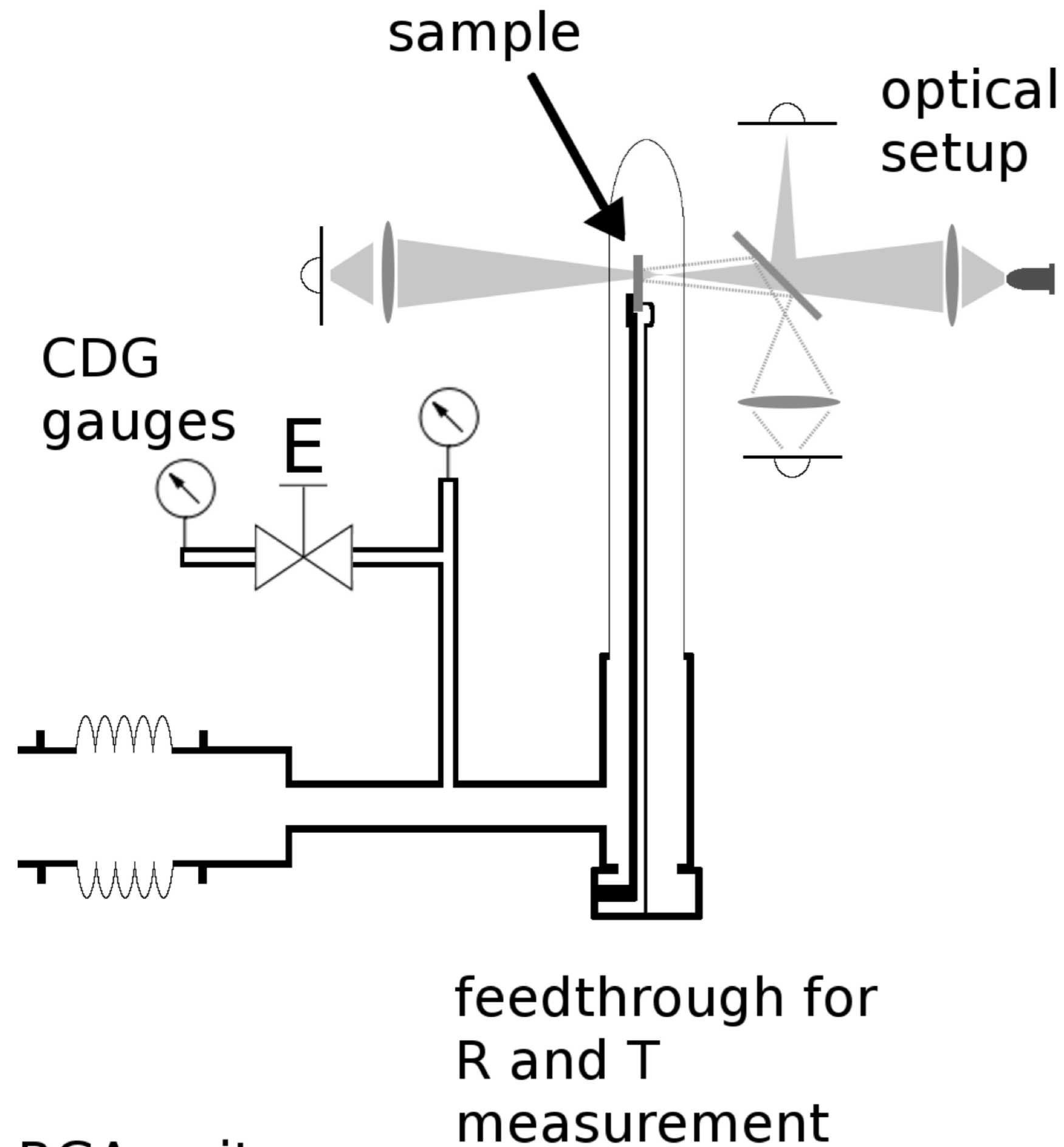

- 120 C
- 150 C
- 160 C
- 170 C
- 180 C
- 190 C
- 200 C
- 220 C
- 230 C
- 240 C
- 250 C
- 260 C

Proximity and finite size effects on hydrogen absorption in vanadium

Phase boundaries and hydrogen locations

Excess resistivity $\Delta\rho$ – electron scattering from H as impurities

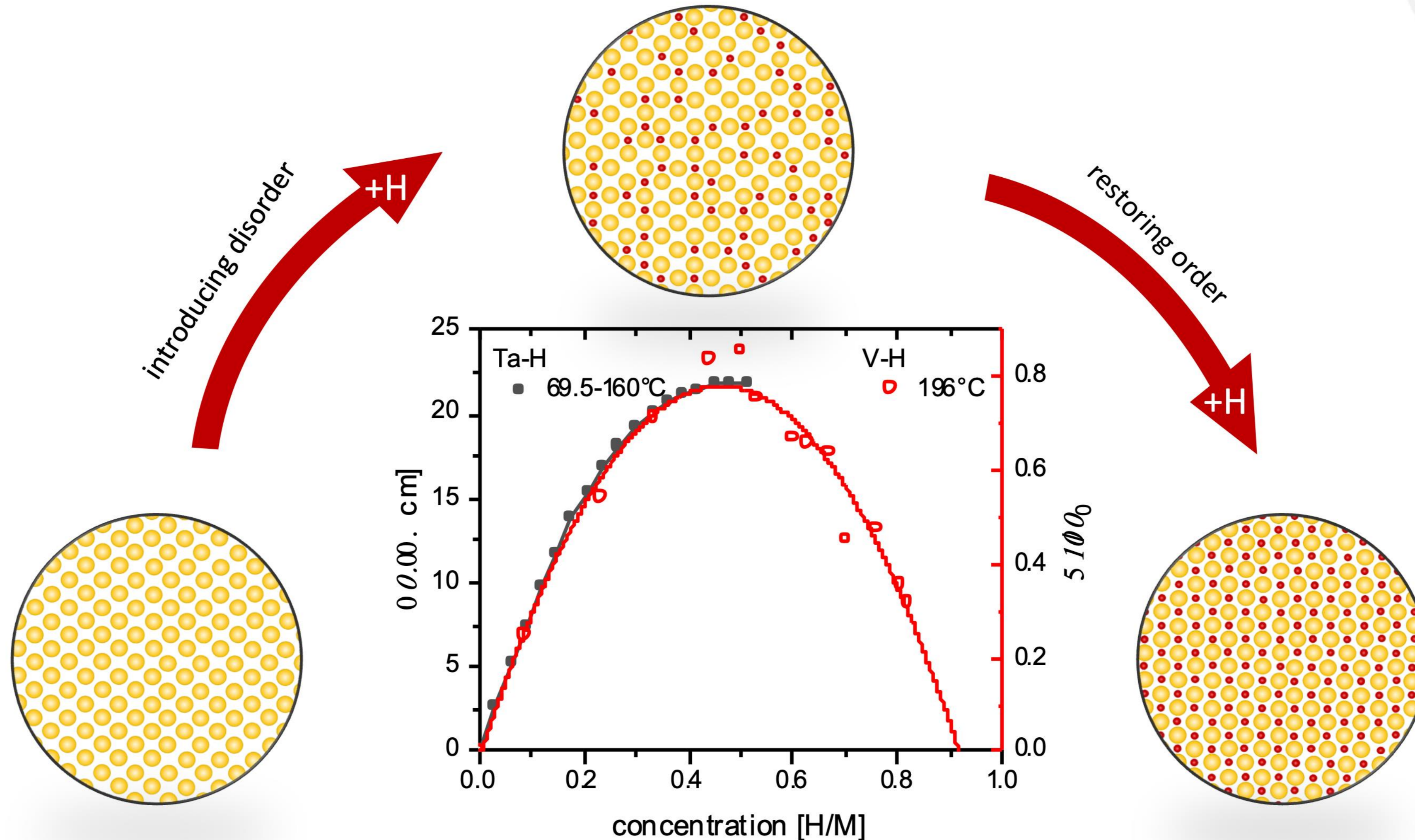

J.A. Pryde, T. Song, *Acta Mater.* 19 (1971)
M.W. Pershing et al., *J. Less-Common. Met.* 75 (1980)



In-situ gas loading environment on Super ADAM

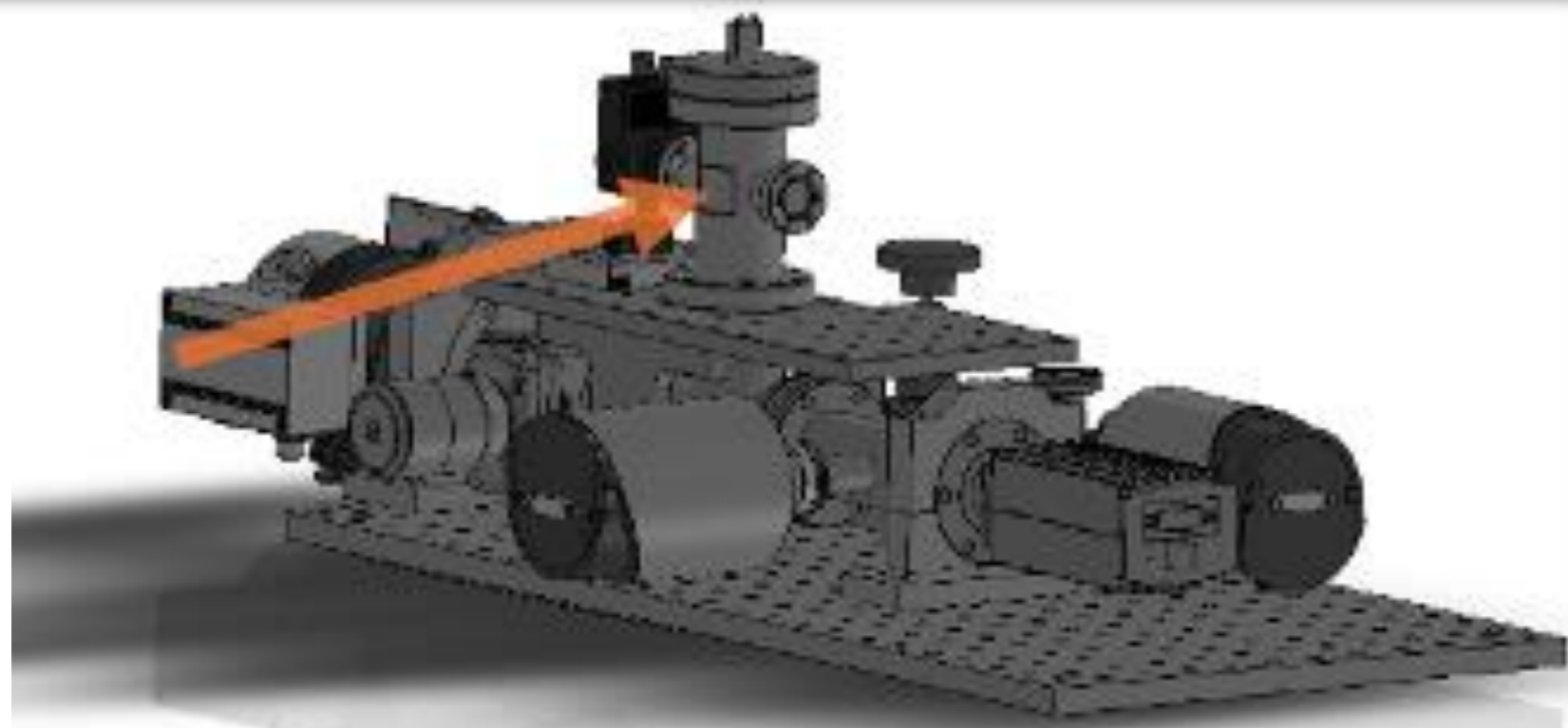

- Ultra high vacuum P : 1e-10 mbar
- Temperature sensor on the sample
- T : 293 - 493 K
- P : 1e-4 - 1e3 mbar
- Ultra pure hydrogen and deuterium
- Optical Transmission
- Optical Reflectance possible
- Raman scattering possible

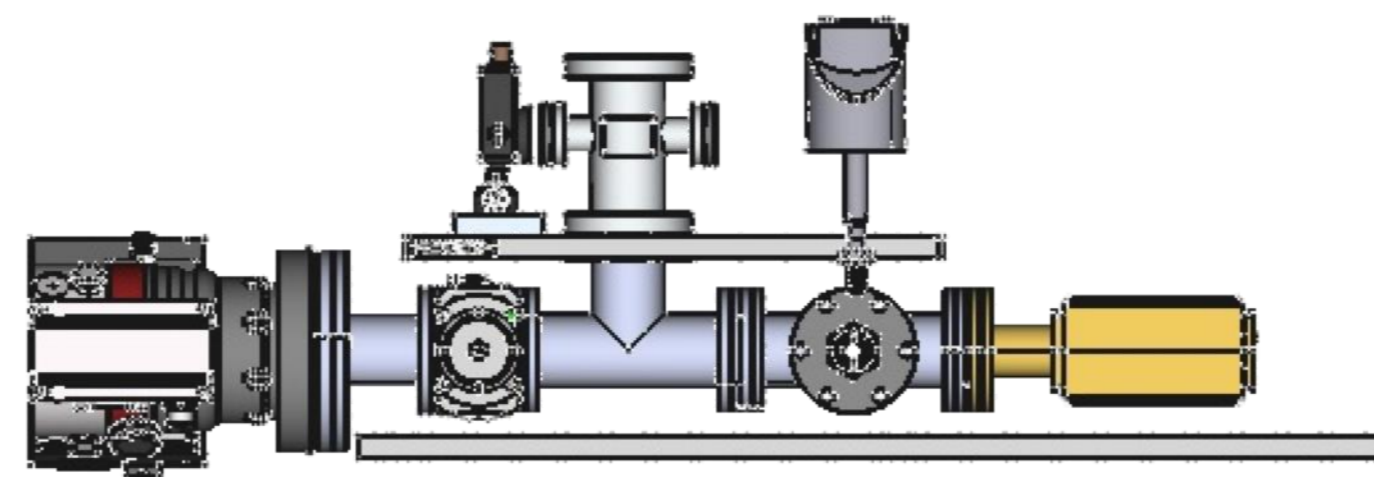
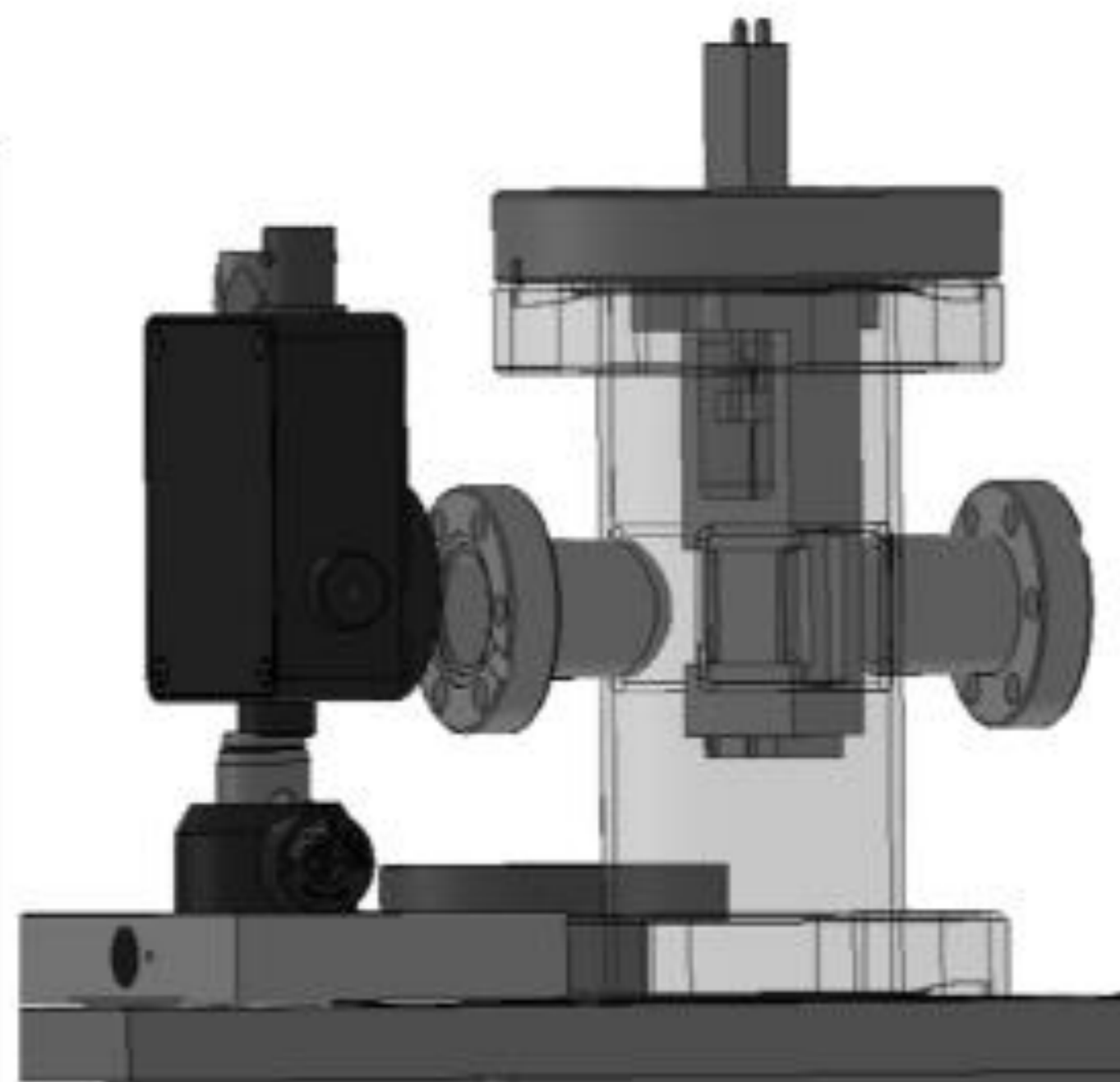

Neutron reflectometry

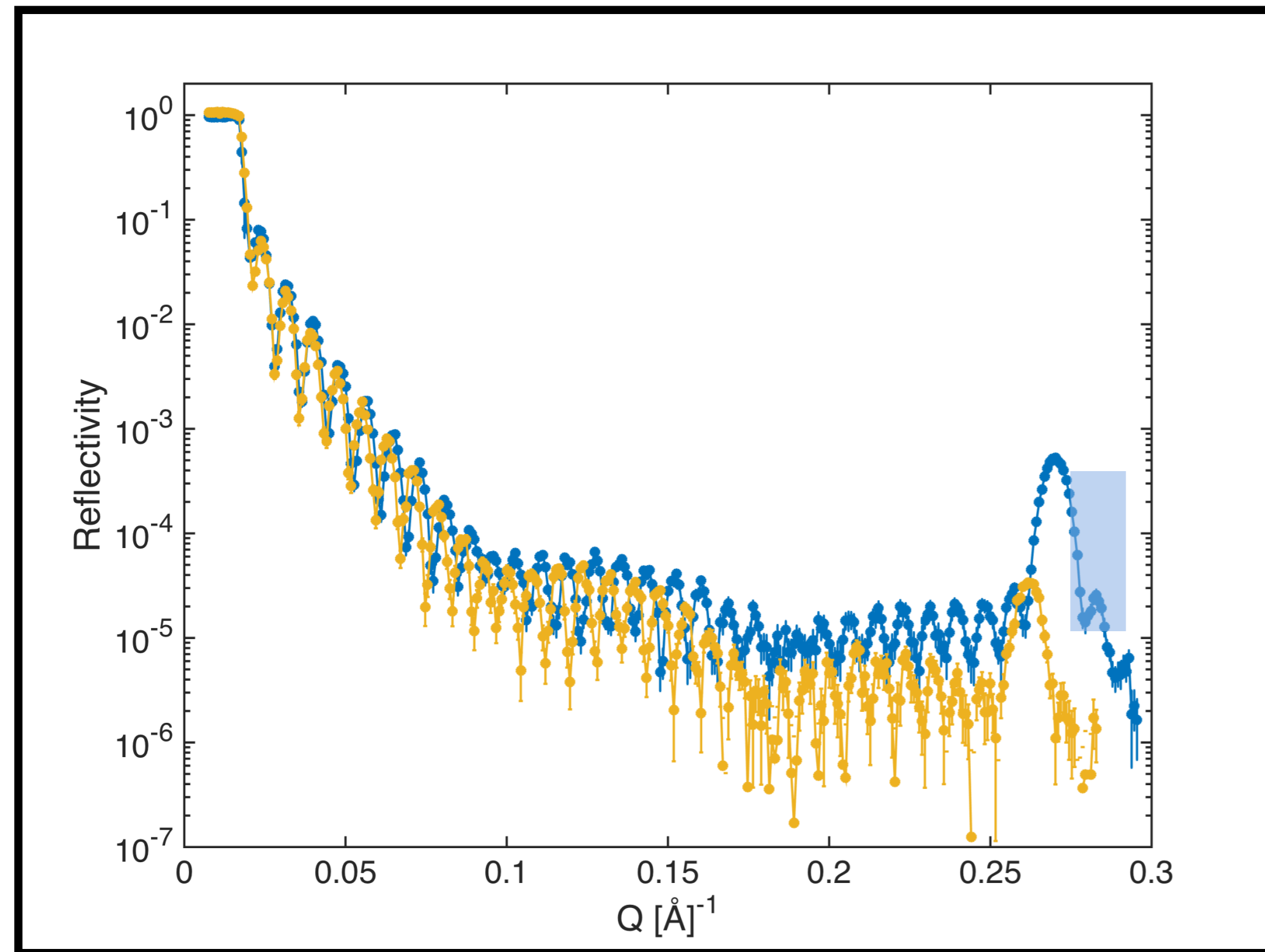

Hydrogen concentration manifests as changes in refractive index for neutrons

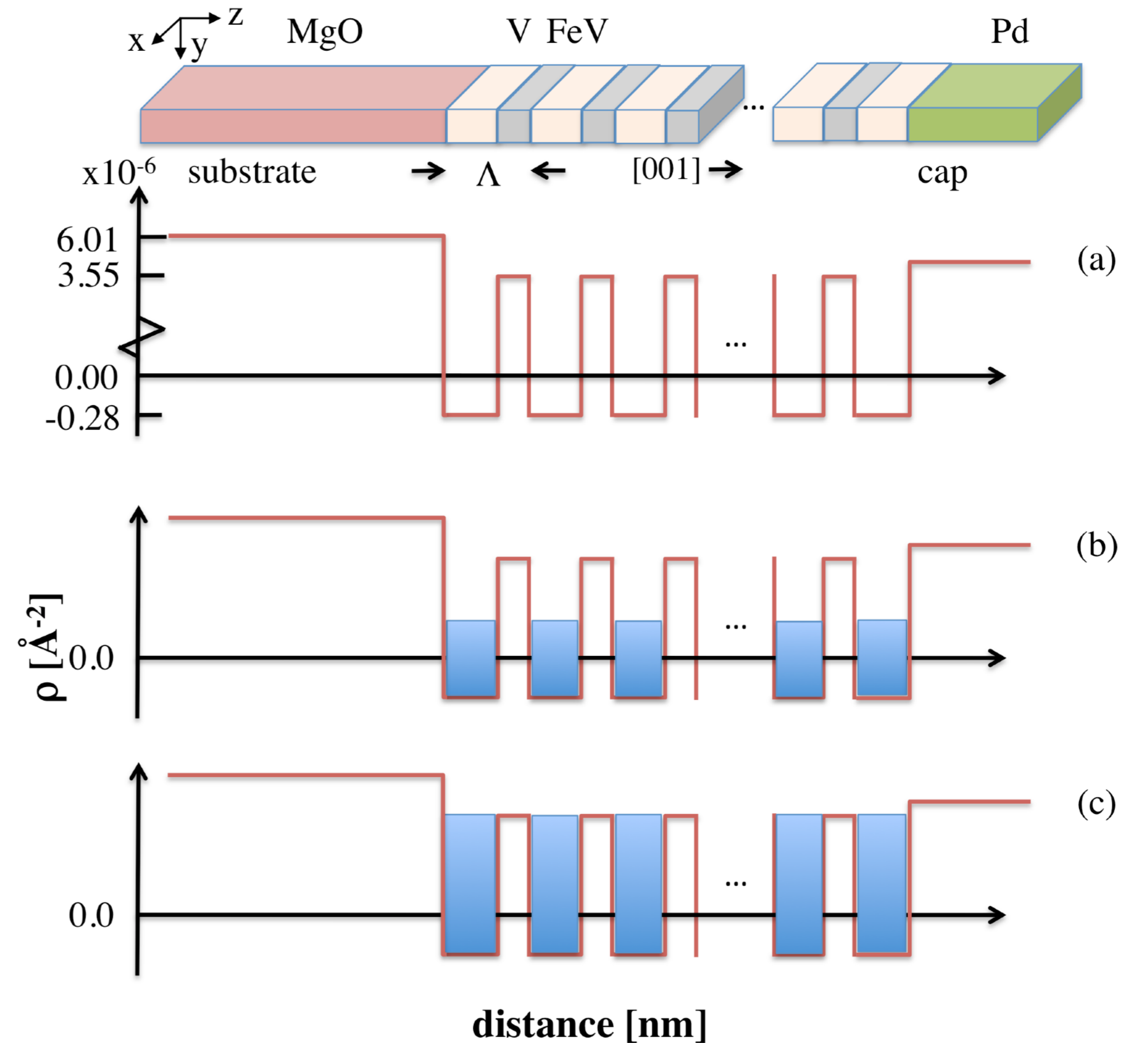

neutrons $n \approx 1 - \frac{b\lambda^2}{2\pi} \frac{N_a}{V} \quad \rho_b = b \frac{N_a}{V}$

Lattice expansion

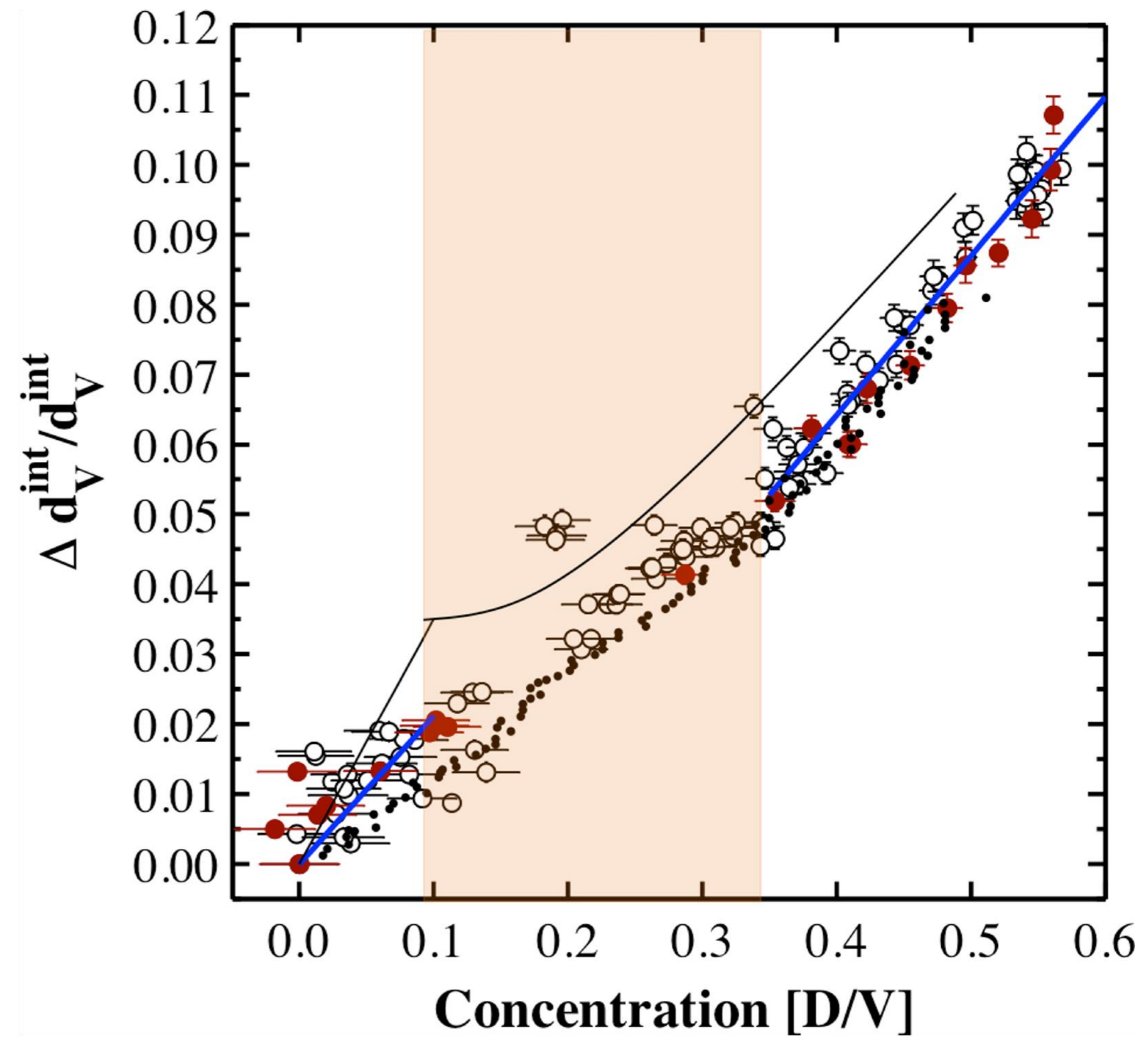
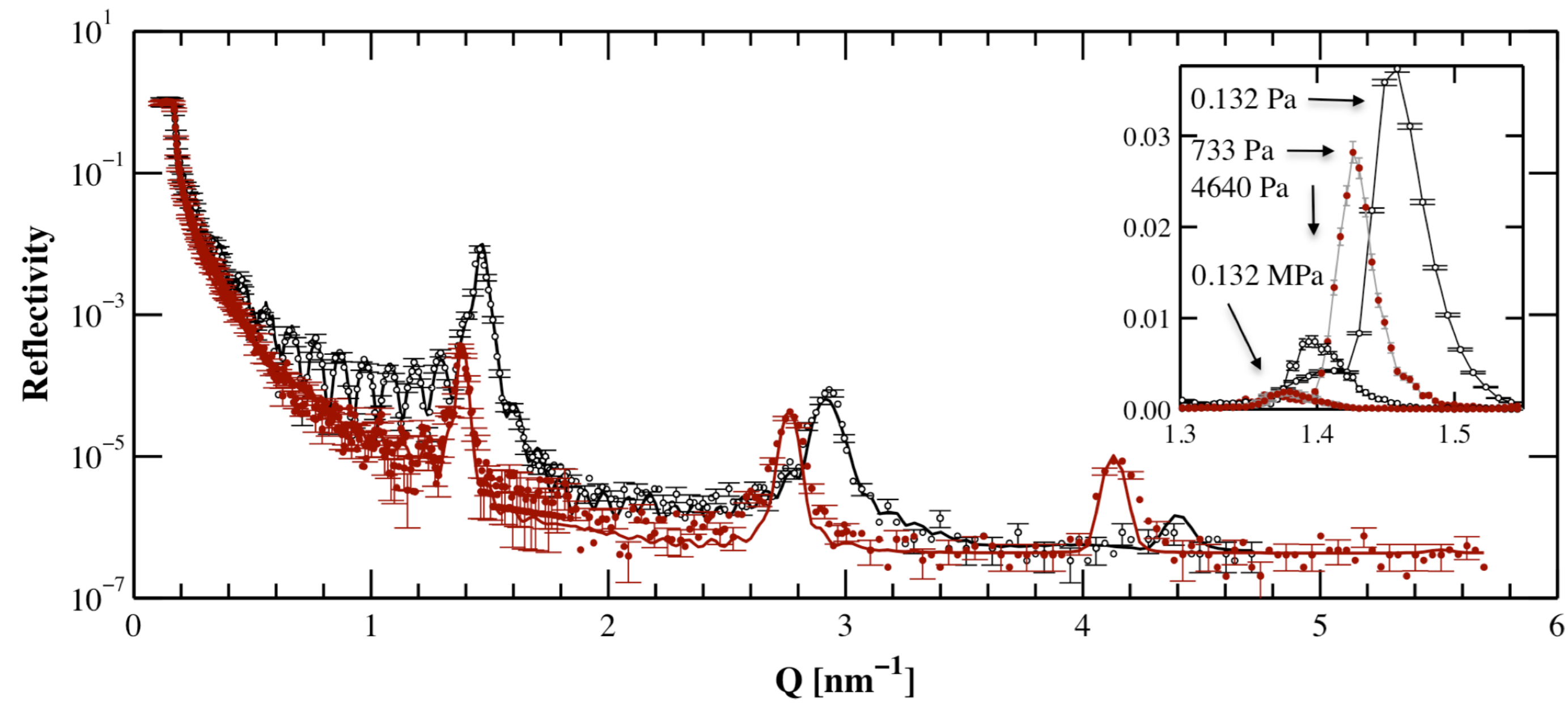

Finite size effect

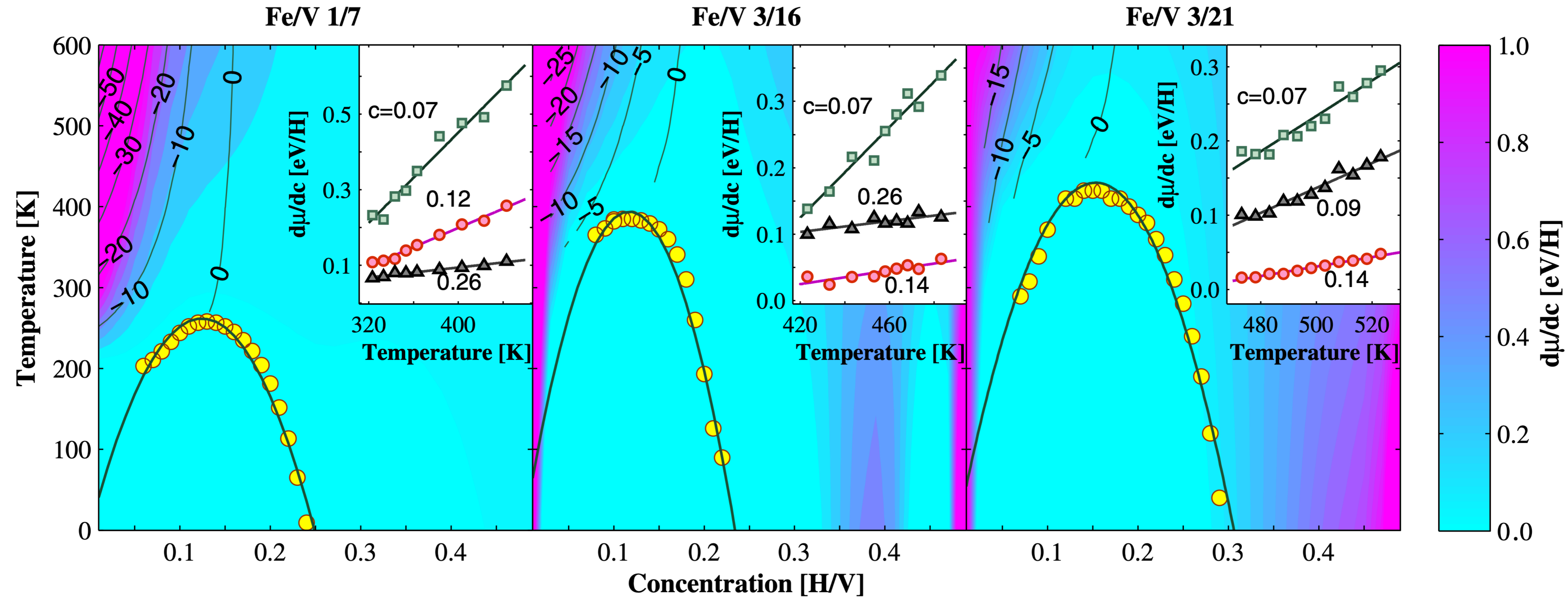

Finite size scaling

Condition for critical point: $\frac{\partial \mu}{\partial c} = \frac{\partial^2 \mu}{\partial c^2} = 0$

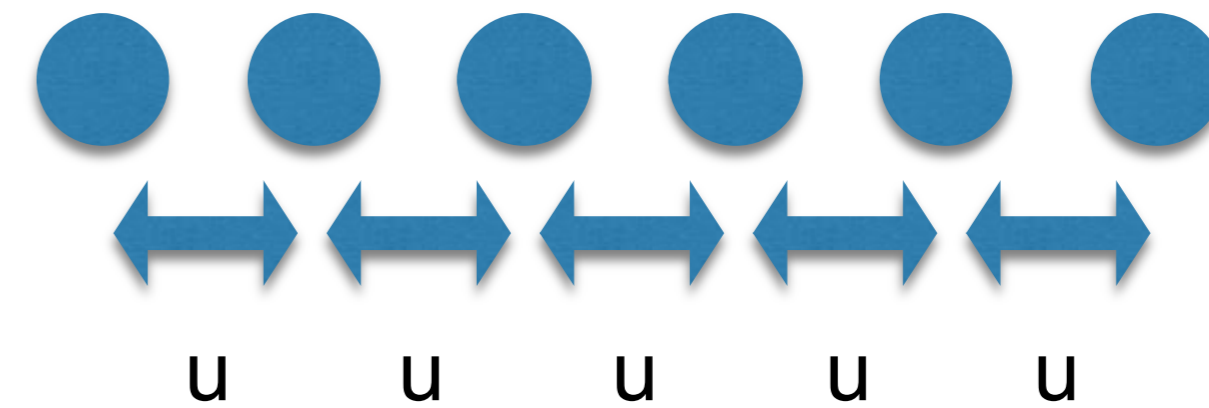
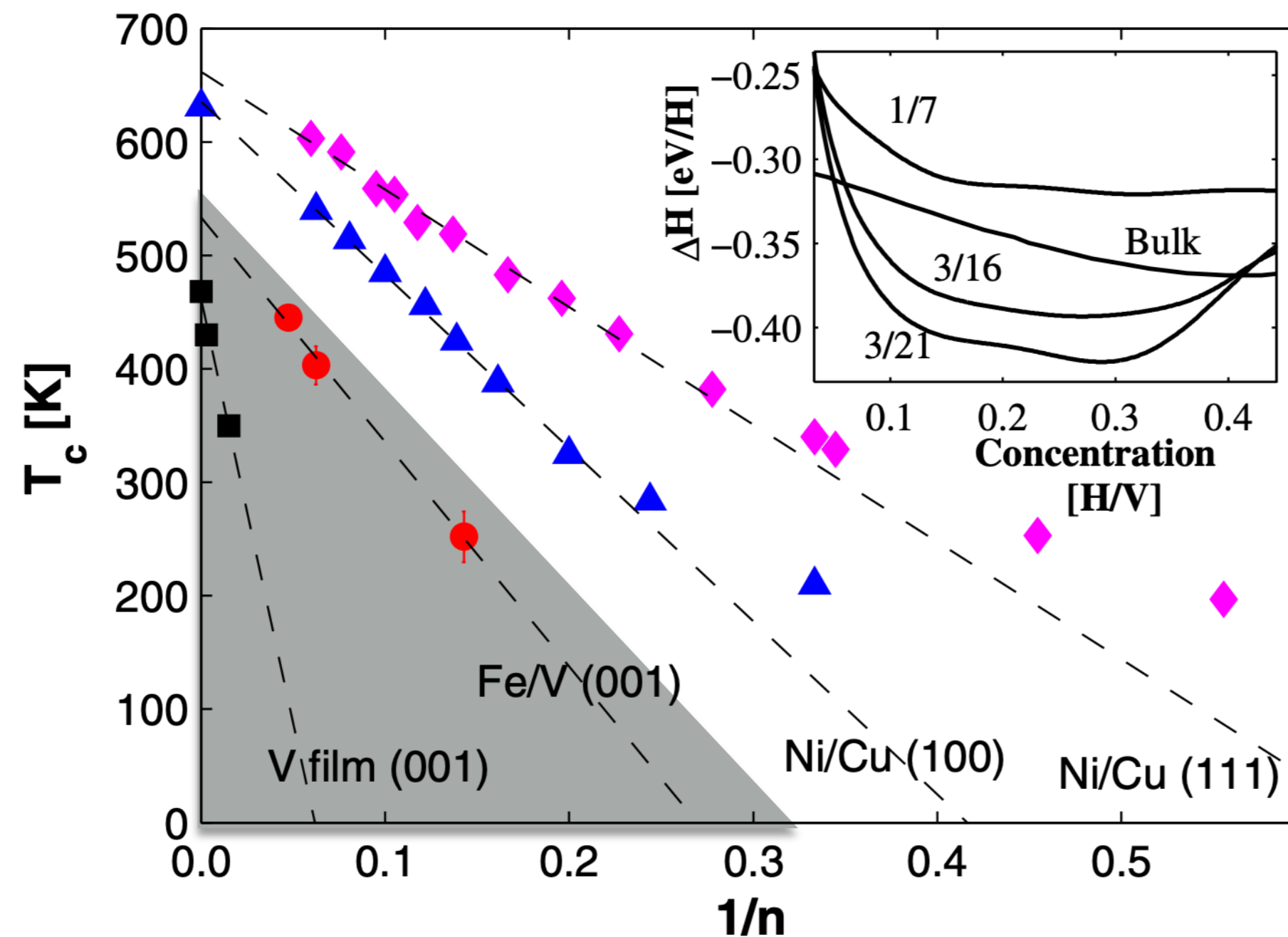

$$T_{crit} \sim \langle E \rangle \sim \sum_{i=1}^{n-1} \frac{u_i}{n} \sim u \frac{n-1}{n}$$

Finite size scaling calculated from mean interaction: $T_{crit} = T_{crit,\infty} \left(1 - \frac{1 + 2\Delta n}{n} \right)$

Influence of deuterium induced lattice expansion on optical transmission

Neutron reflectivity measurements:

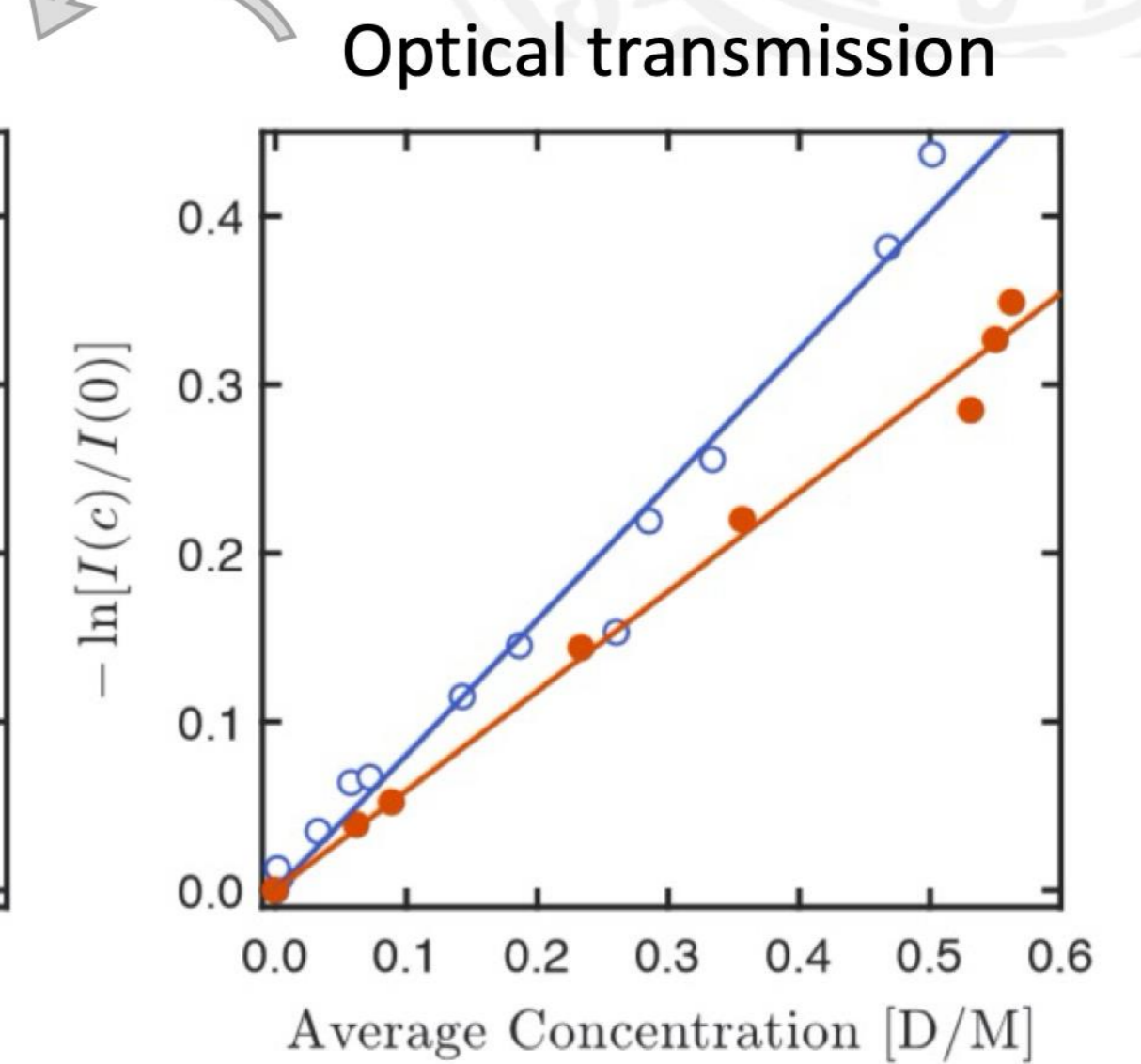
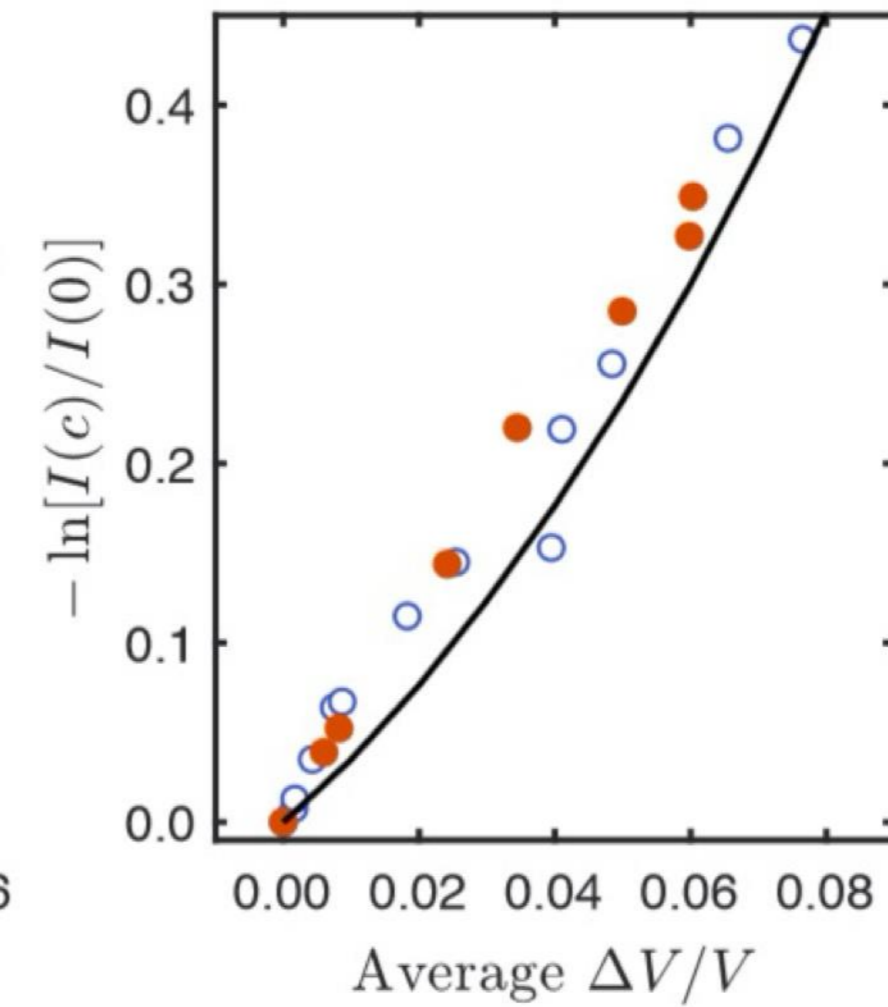
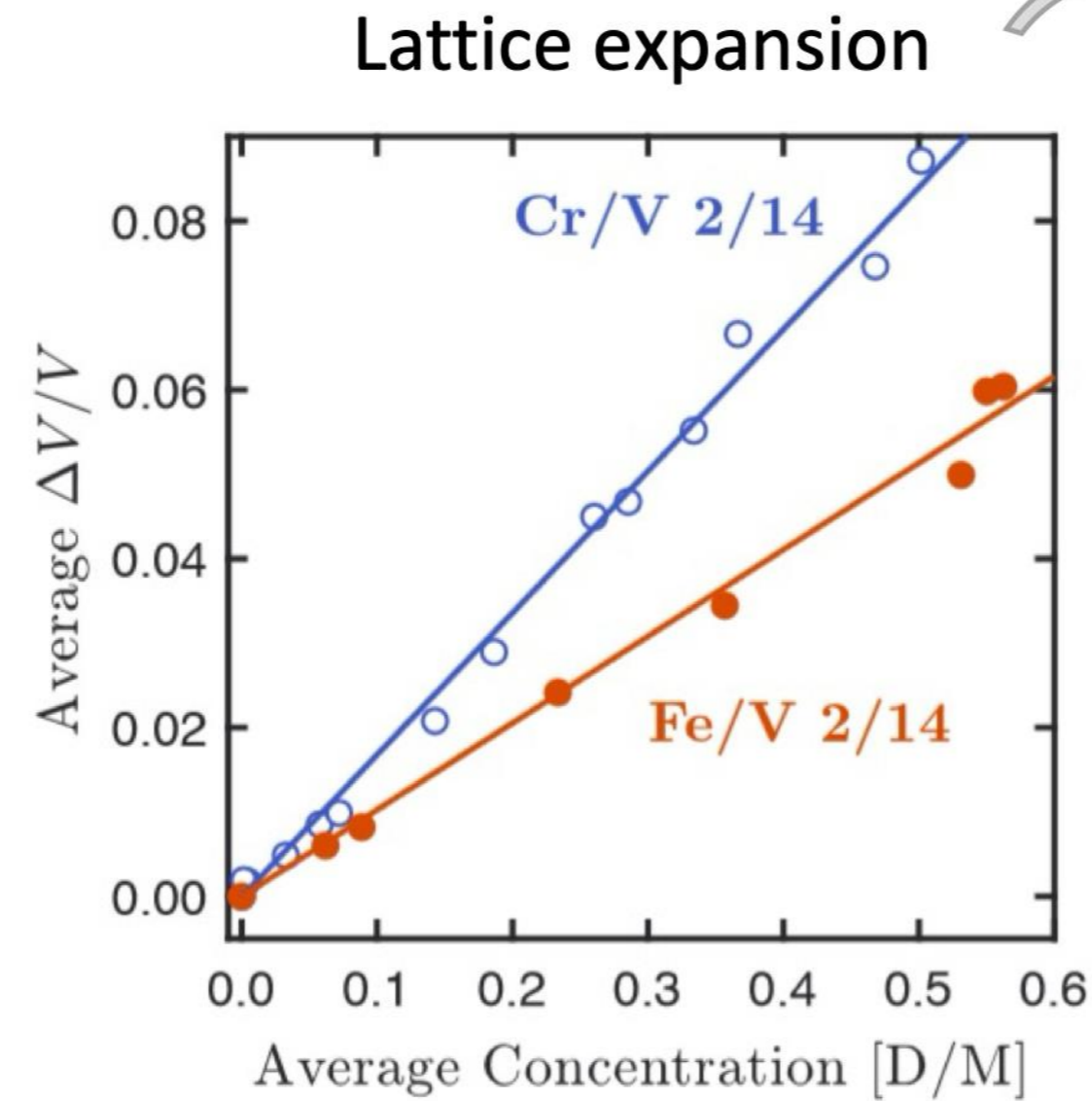
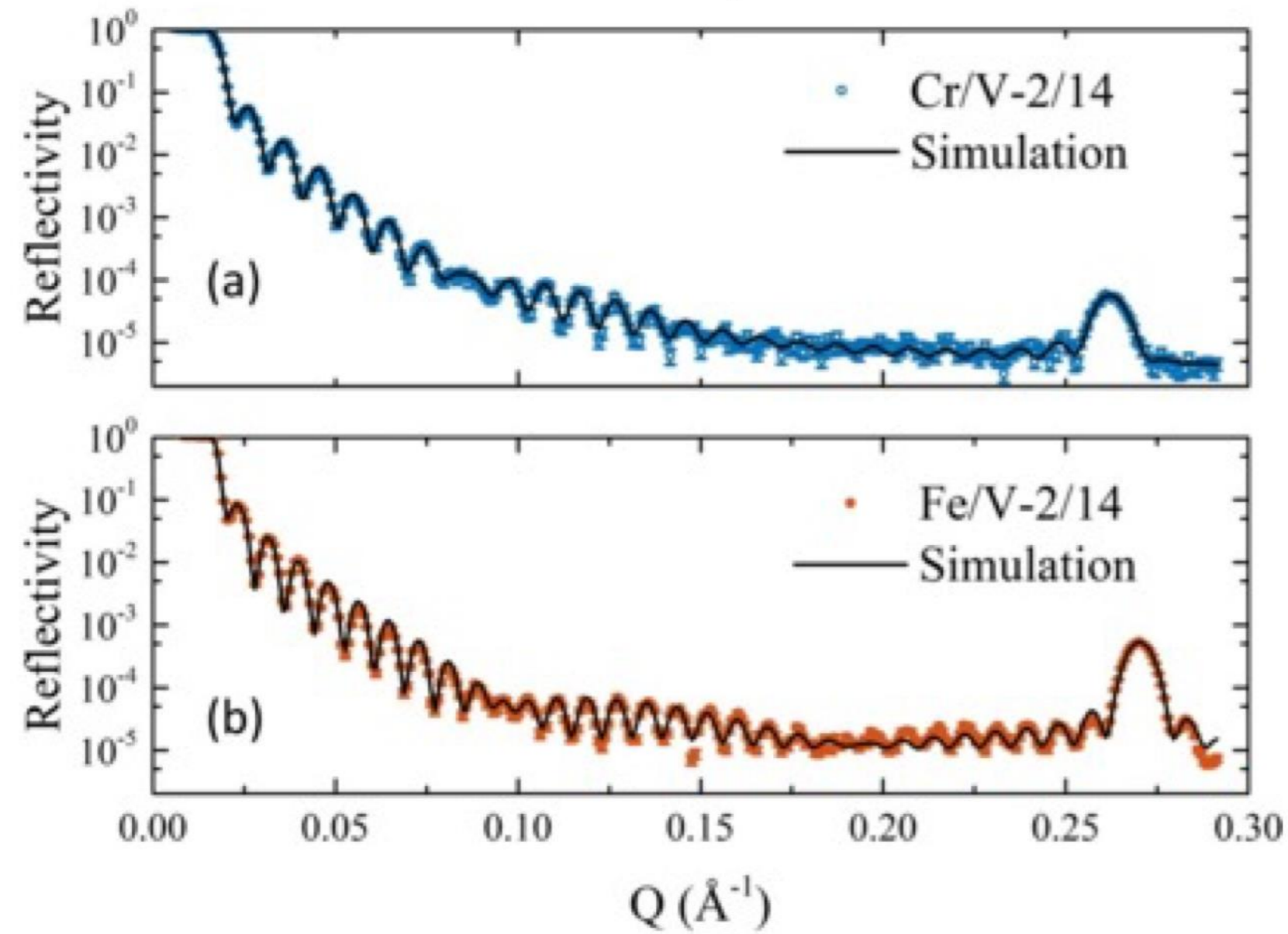

Reproduced from: S.A. Droulias. PhD thesis, Uppsala Universitet, 2018.

Change in site occupancy as cause for different lattice expansion?

Is the optical transmission driven by lattice expansion?



Ion beam techniques

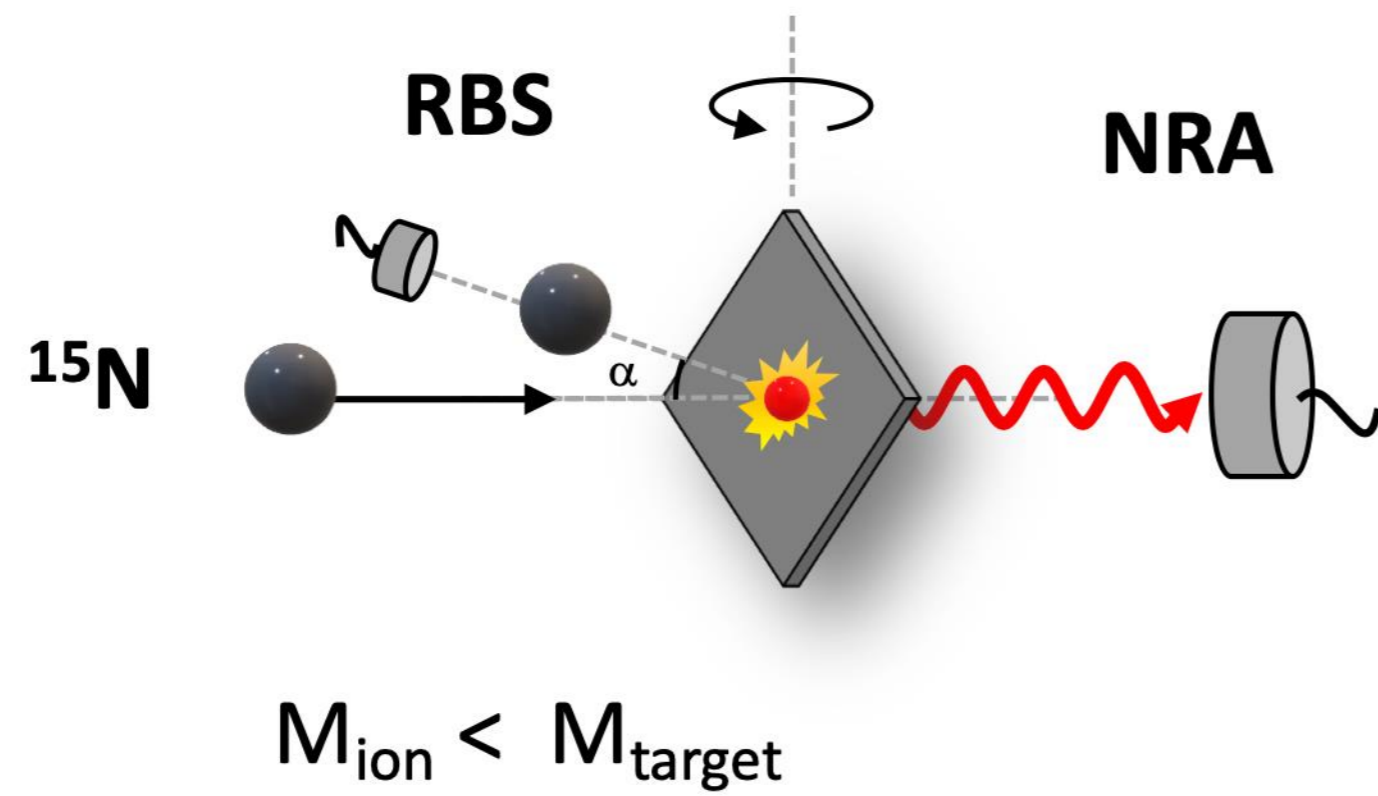

Resonant Nuclear Reaction Analysis

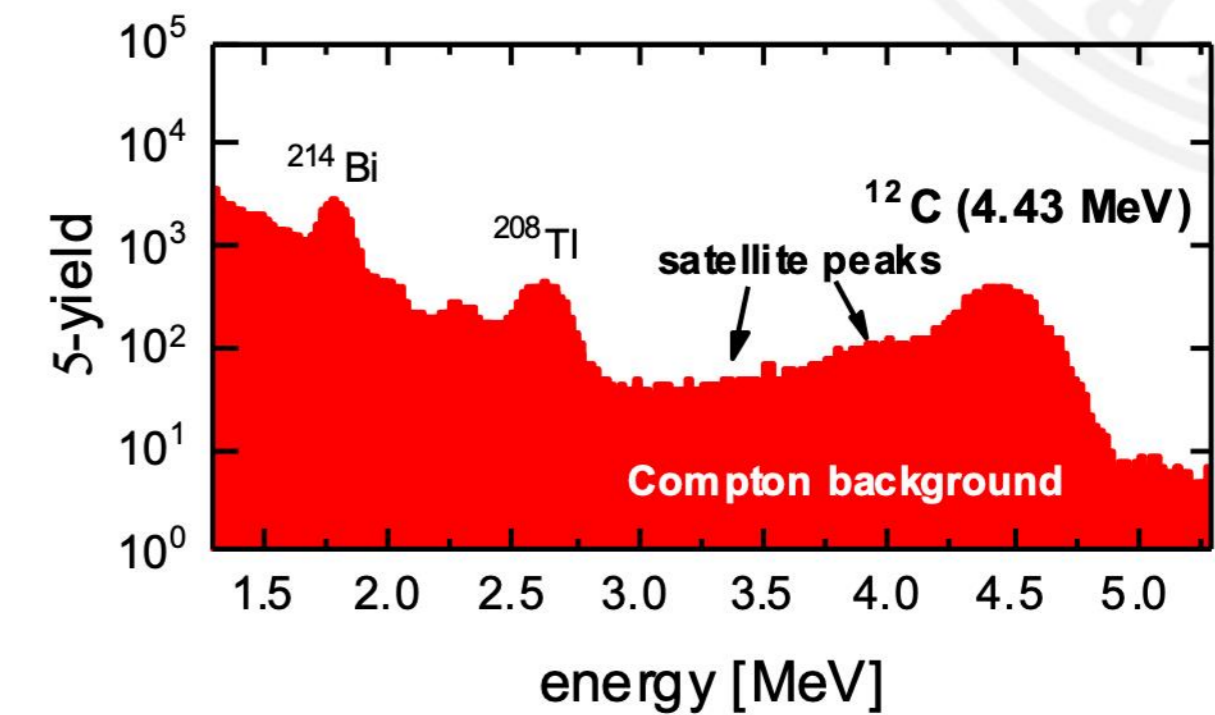
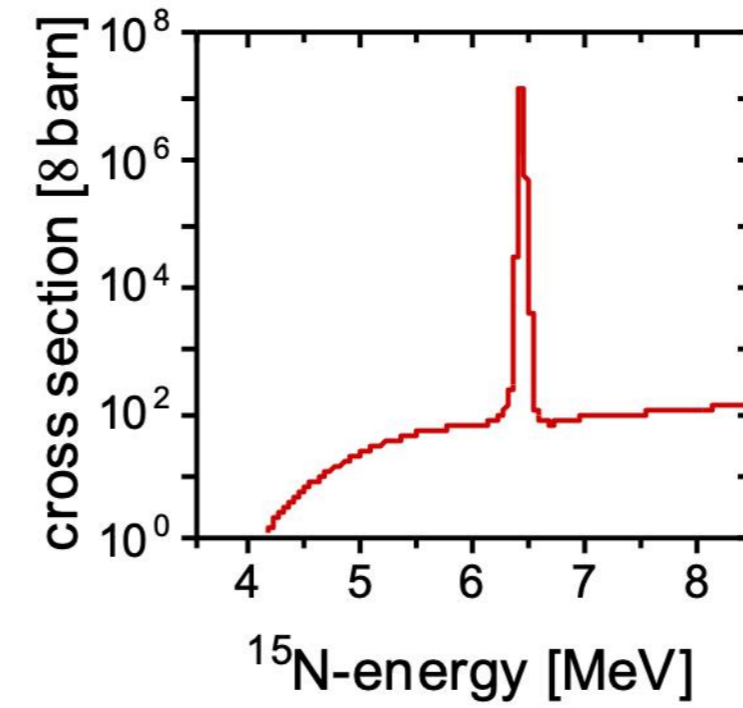
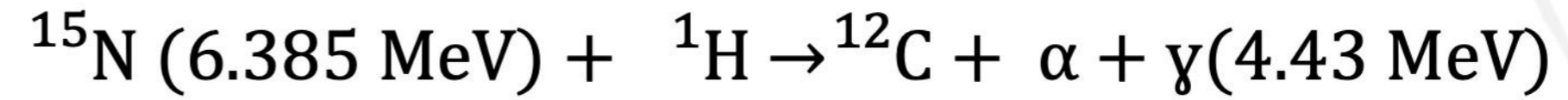

Rutherford Backscattering Spectrometry

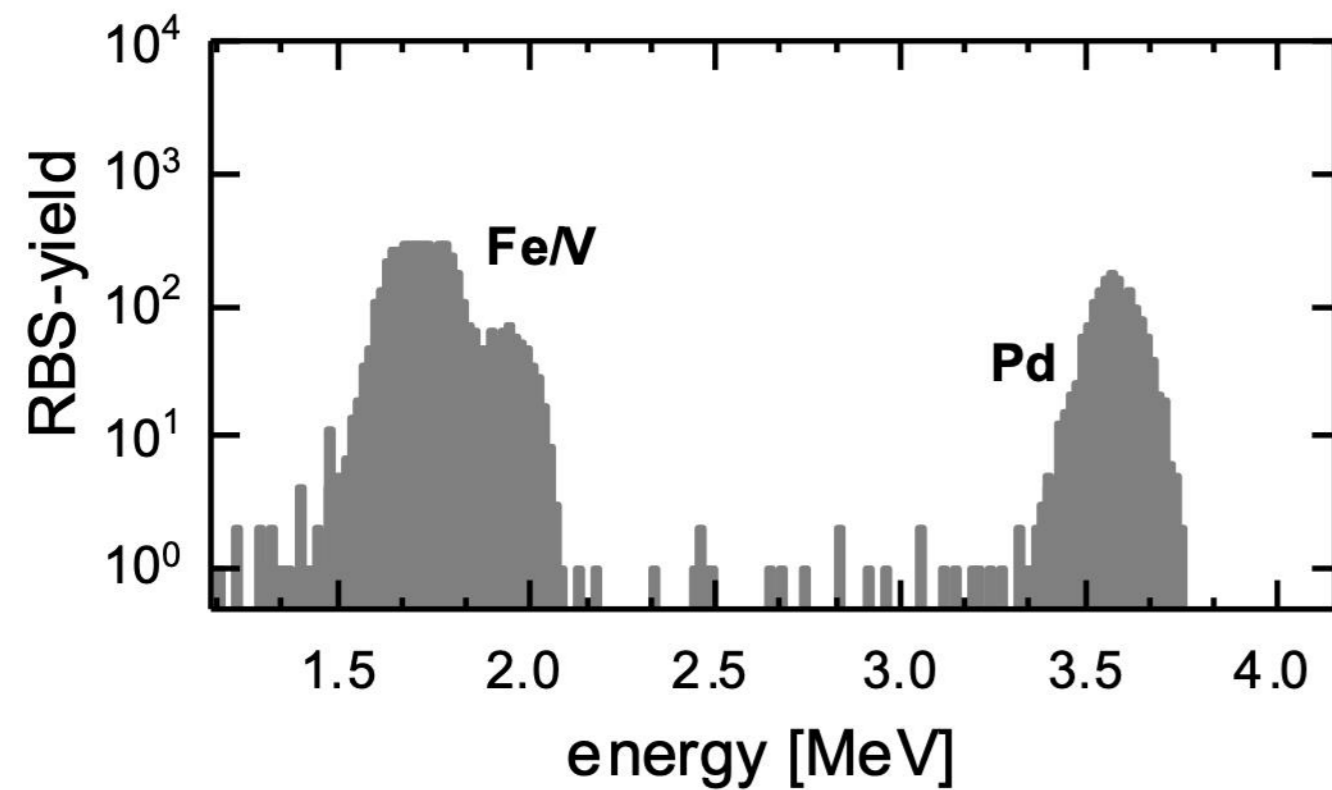

☐ metal composition

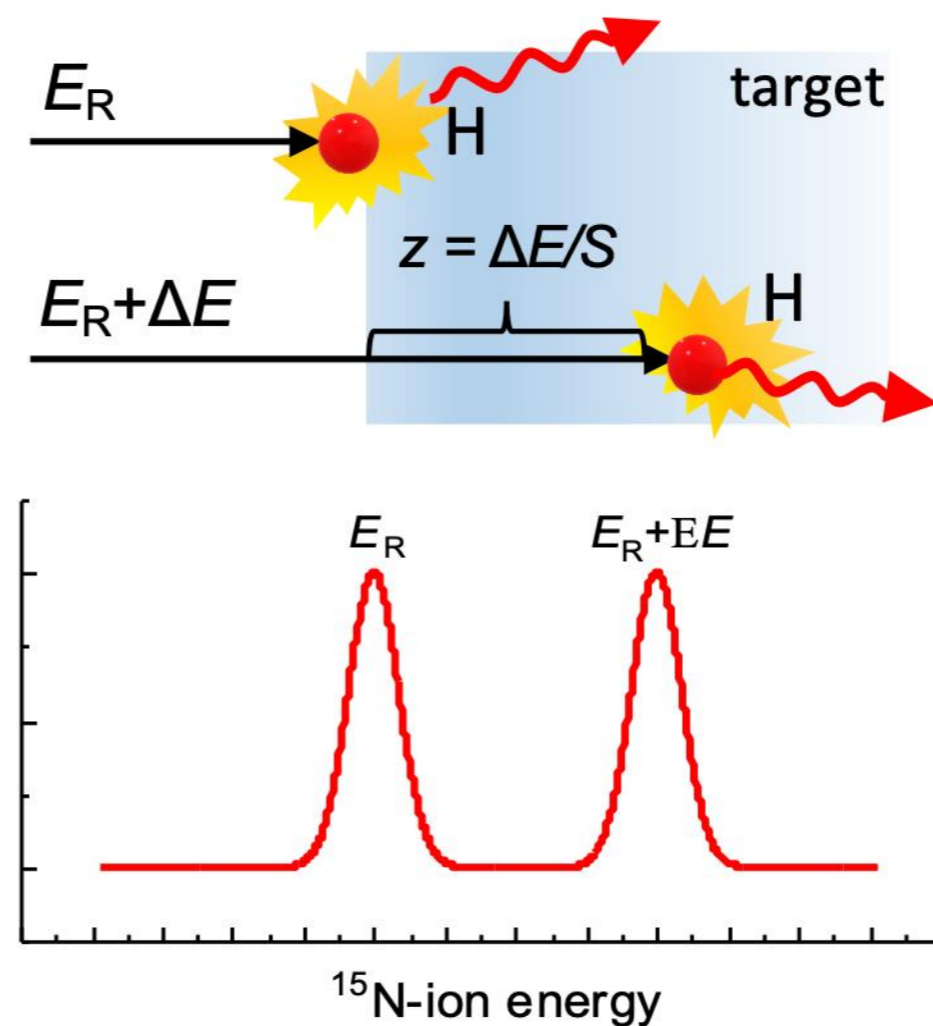

☐ H-concentration profile

Poster P2-F5-8 at Thursday 30/5 17:30:

Accurate measurement of hydrogen concentration in hydrogen-rich transition metal hydrides using electronic excitations by MeV-ions

Real space crystallography in thin films – Ion channeling

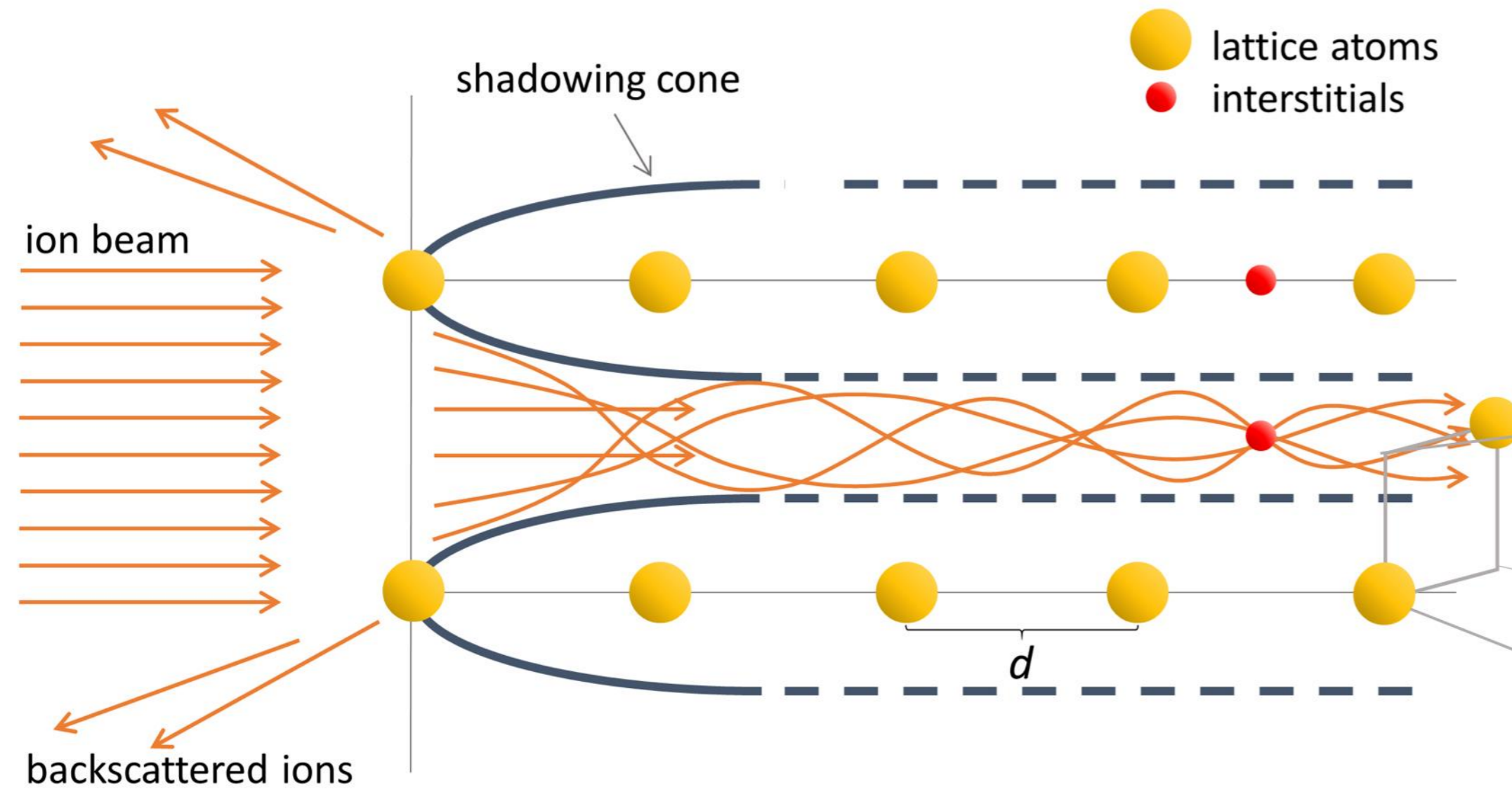
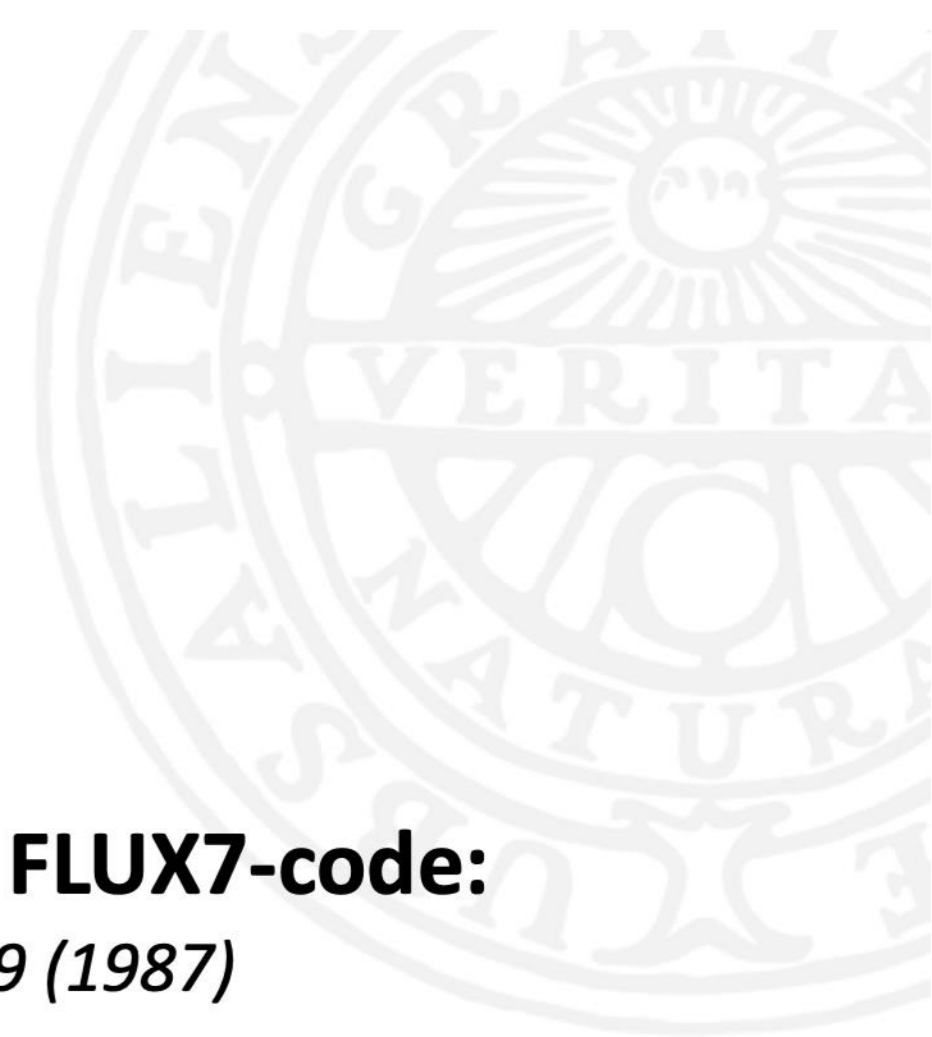

Simulation of ion trajectories FLUX7-code:

P.J.M. Smulders, D.O. Boerma, NIMB 29 (1987)

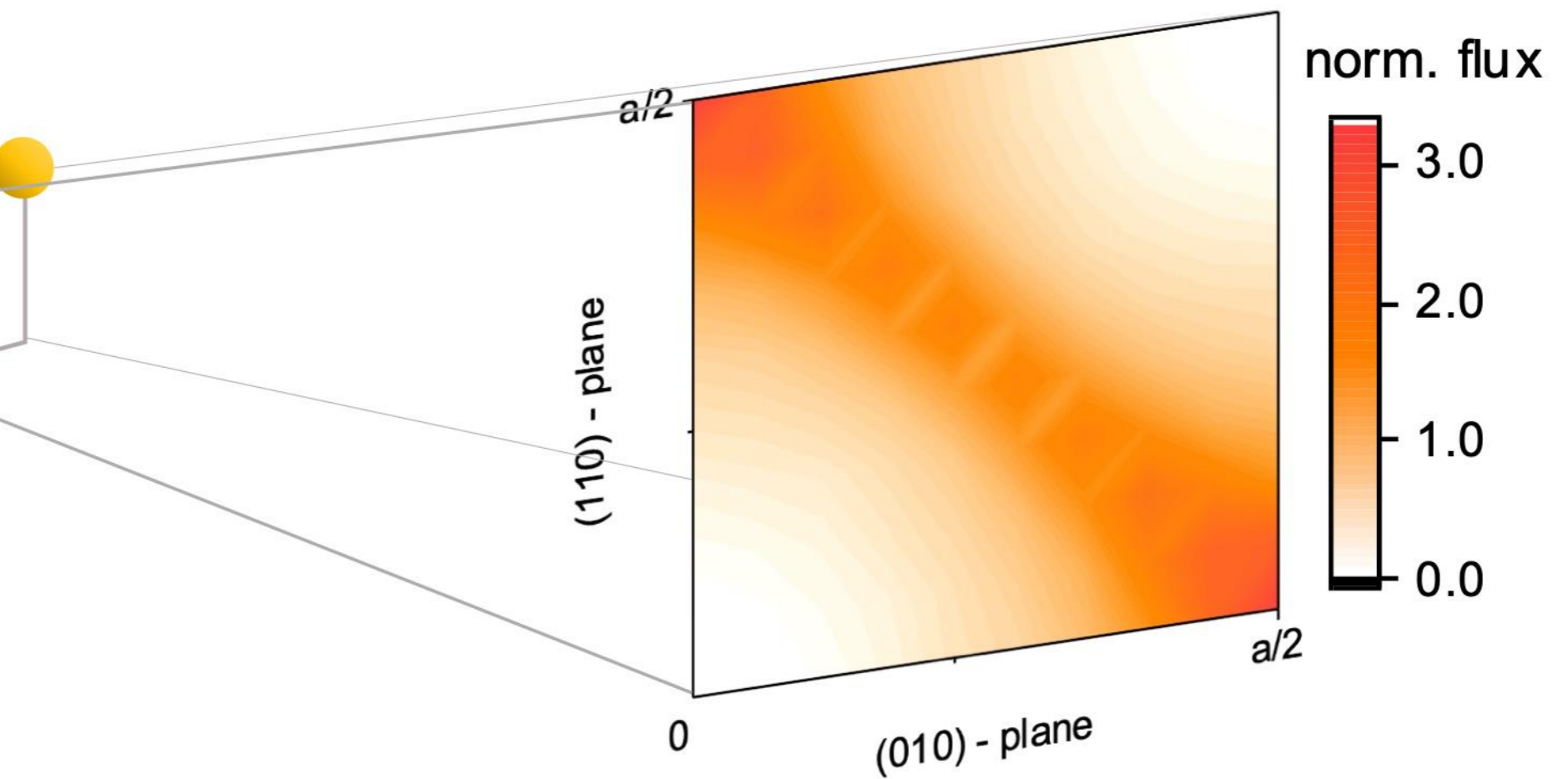

- yield decreases for shadowed H
- yield increases for H residing in the channel

NEP - nuclear encounter probability

$$\propto \text{RBS}$$

$$\propto \text{NRA}$$



The ultimate detection limit: Interstitial hydrogen



Site Location and thermal vibrational motion

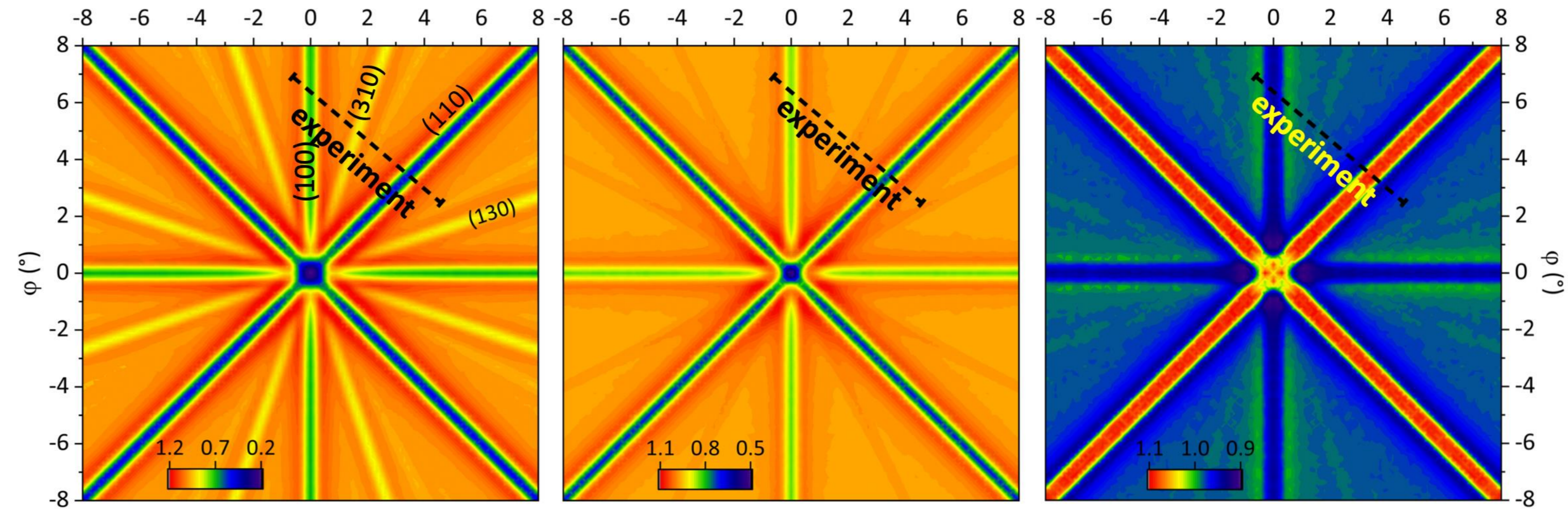
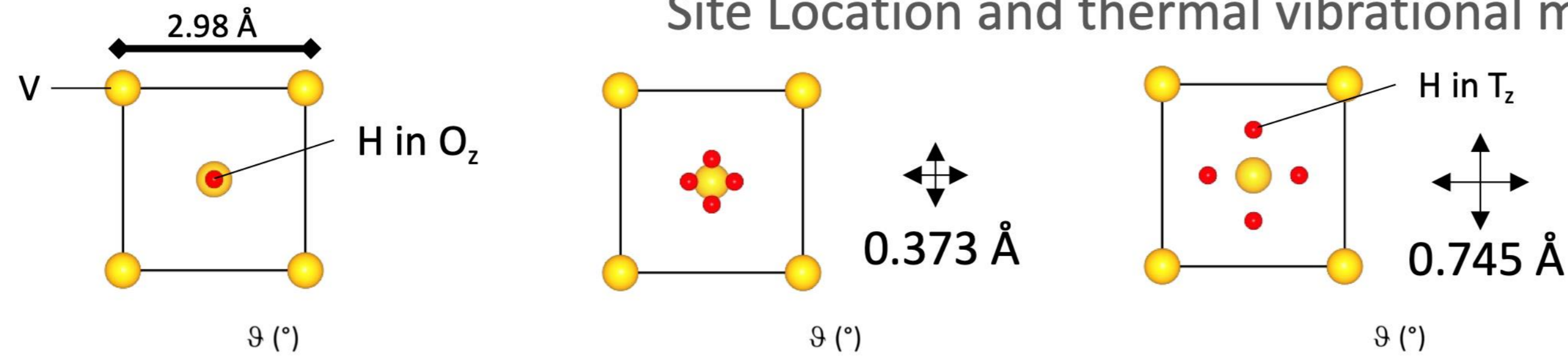

Simulated ^{15}N -NEP to H:
Convolution of vibrating H with ion flux distribution

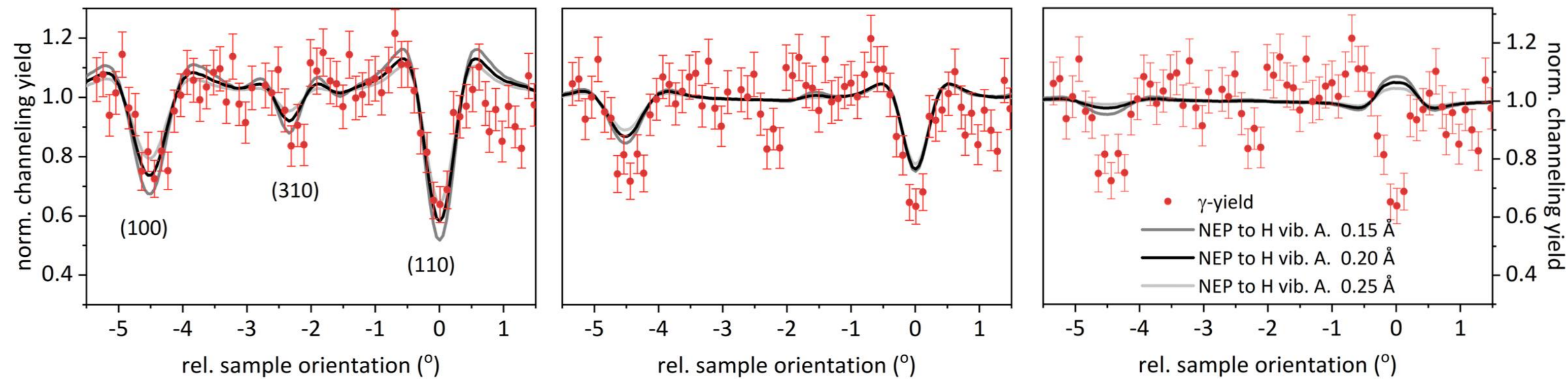

Proximity and finite size effects on hydrogen absorption in vanadium

Phase boundaries and hydrogen locations

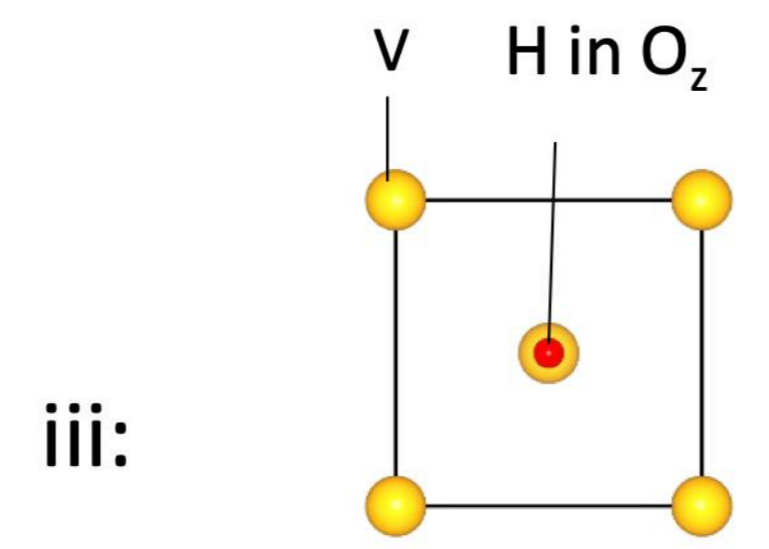
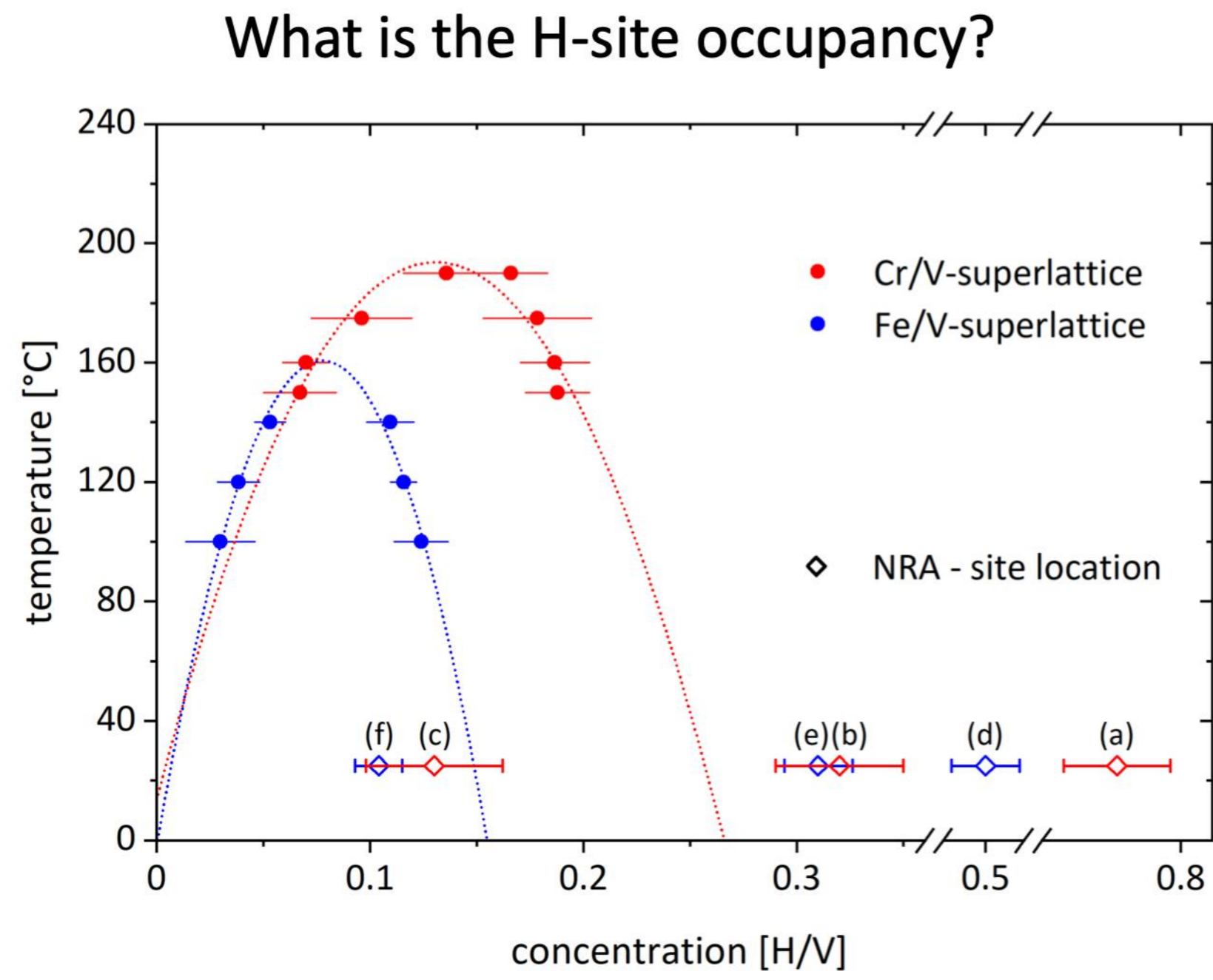

NRA-channeling experiments

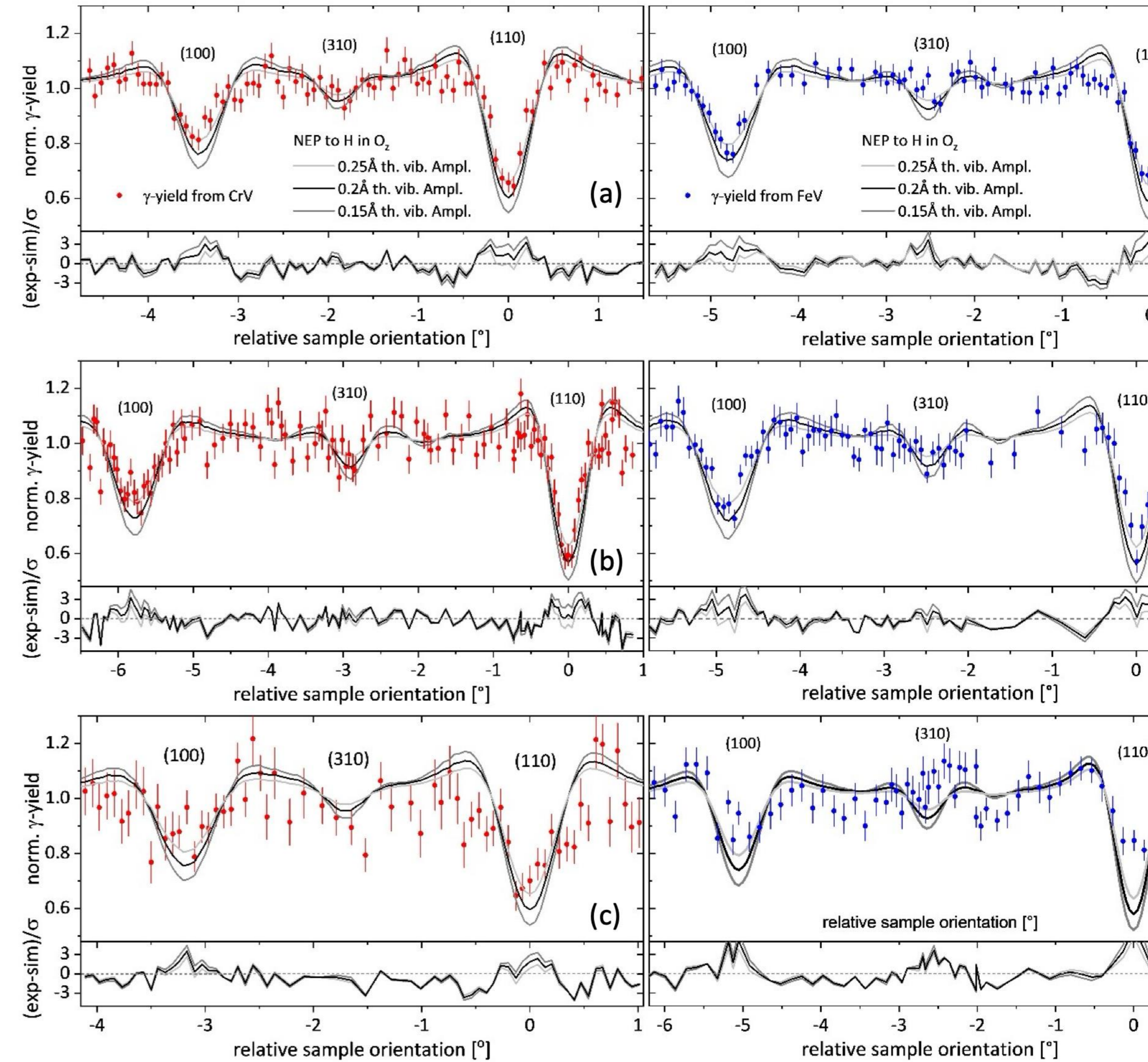

Why disorder?

- **Disorder**

- Breaks local and global symmetries
- No more well-defined directions for diffusion
- Topological frustration
- More open energy landscape
- No grain boundaries
- Large entropy from disorder

- **Limitations**

- Thermal stability
- Cycling
- Brittle?

Information is entropy

"...implies that the coordinates of atoms contain all the information needed to calculate the configurational entropy." – M. Widom 2018

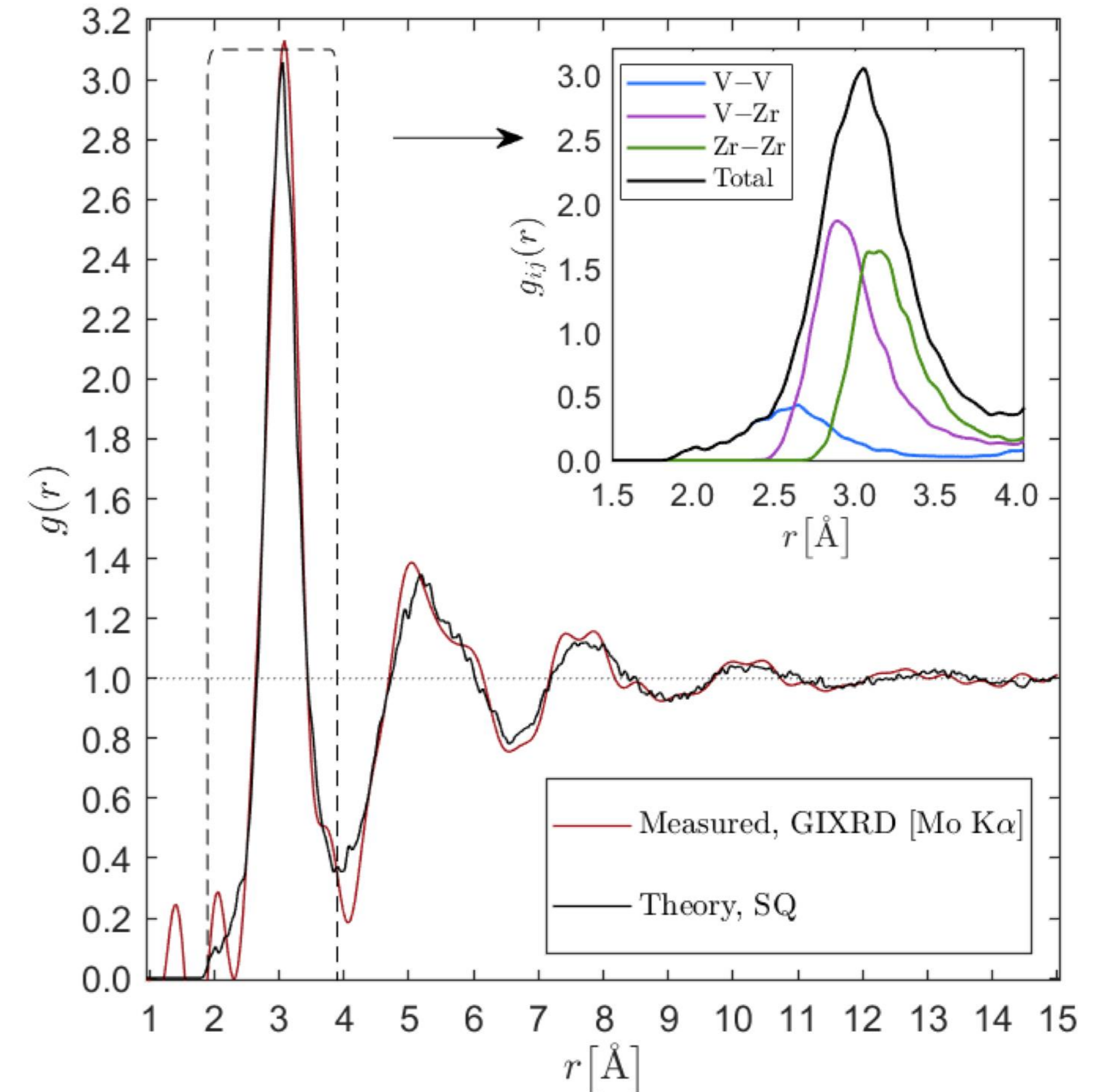
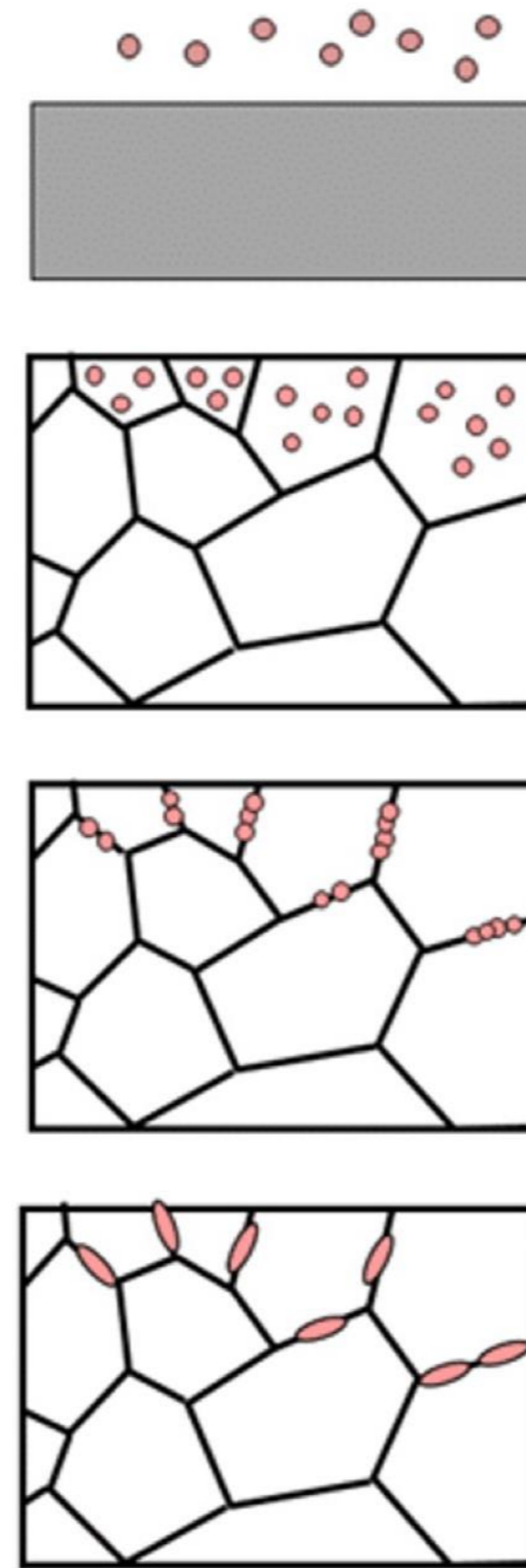

$$S/k_B = - \sum_i p_i \ln p_i$$

$$\Delta S_{\text{info}}[g(r)]/k_B \equiv -\frac{1}{2}\rho \int \mathbf{dr} g(r) \ln g(r)$$

How much can you stretch a metallic glass with hydrogen in one dimension?

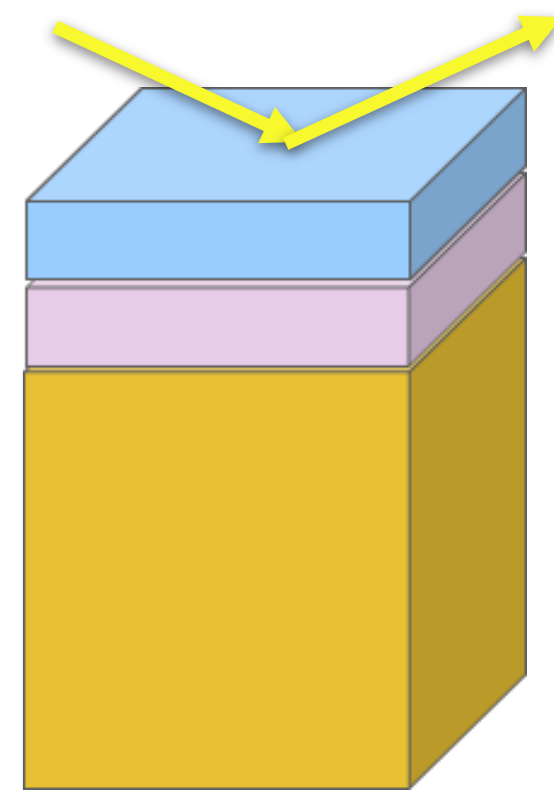
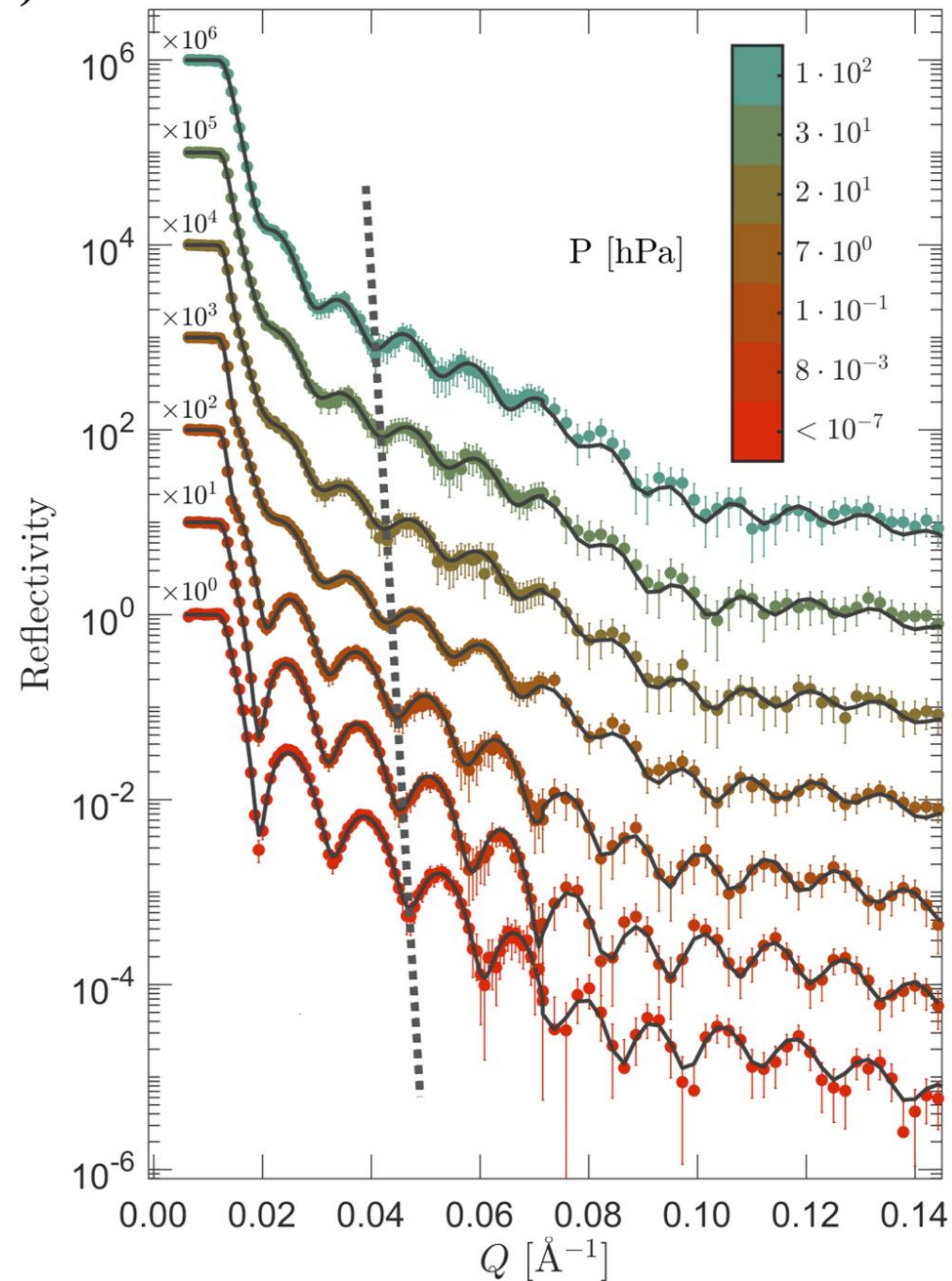
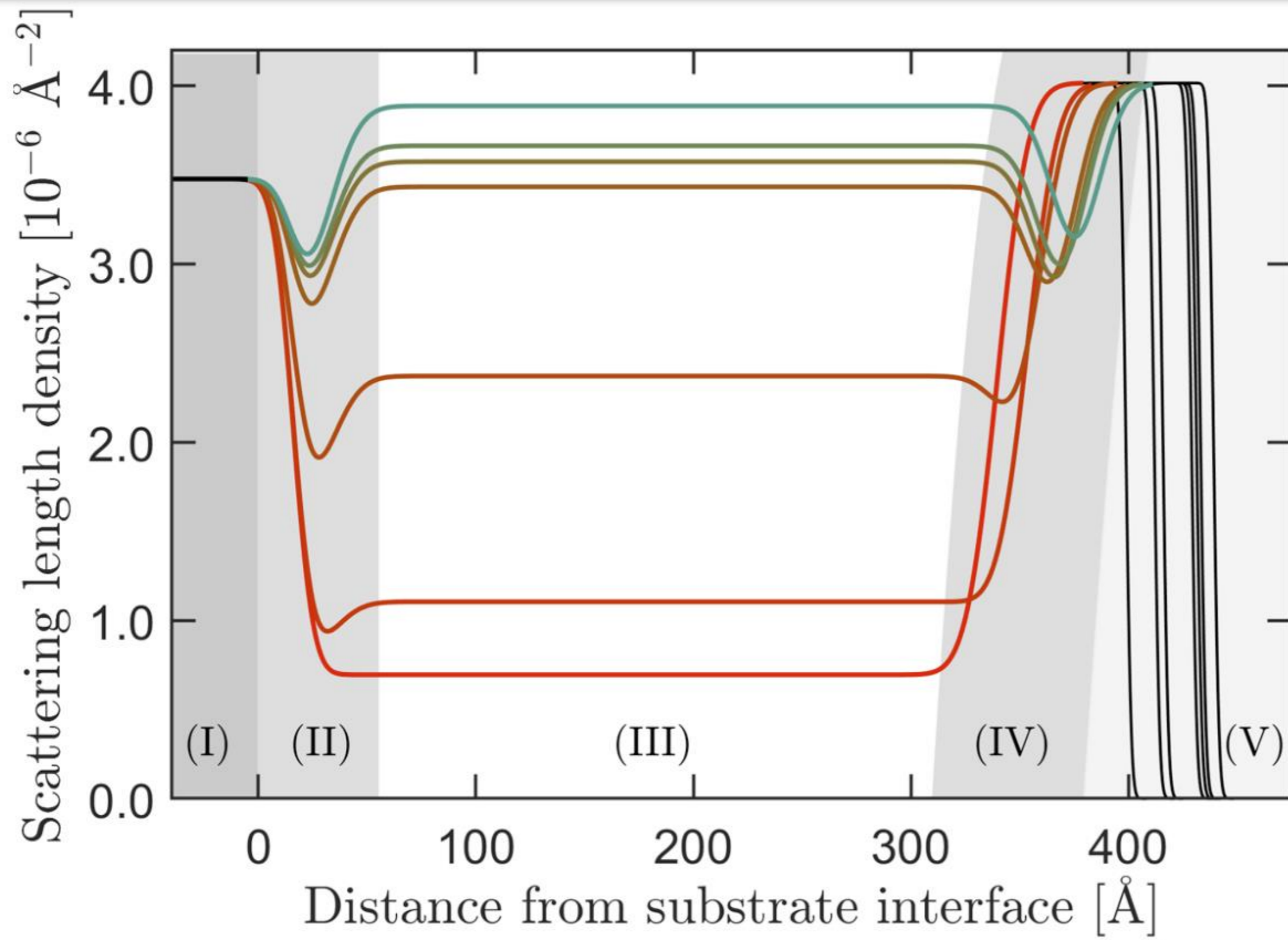

Diffusion

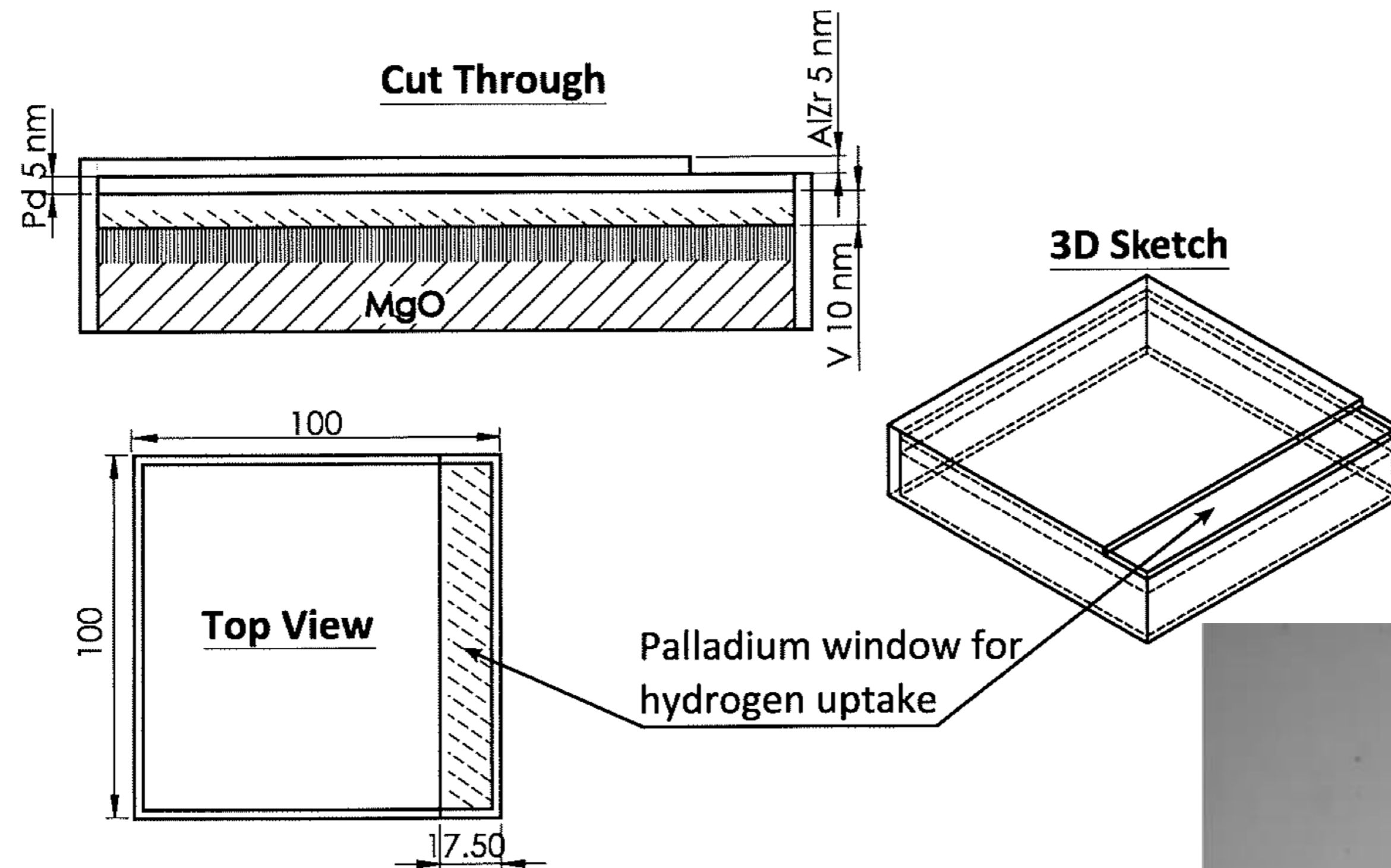

Diffusion equation:

$$\frac{\partial c(x, t)}{\partial t} = \frac{\partial}{\partial x} \left[D \frac{\partial c(x, t)}{\partial x} \right]$$

ARTICLE

Received 5 Mar 2012 | Accepted 9 May 2012 | Published 12 Jun 2012

DOI: 10.1038/ncomms1897

Using light transmission to watch hydrogen diffuse

Gunnar K. Pálsson¹, Andreas Bliersbach¹, Max Wolff¹, Atieh Zamani¹ & Björgvin Hjörvarsson¹



Hydrogen diffusion

50 nm film of vanadium

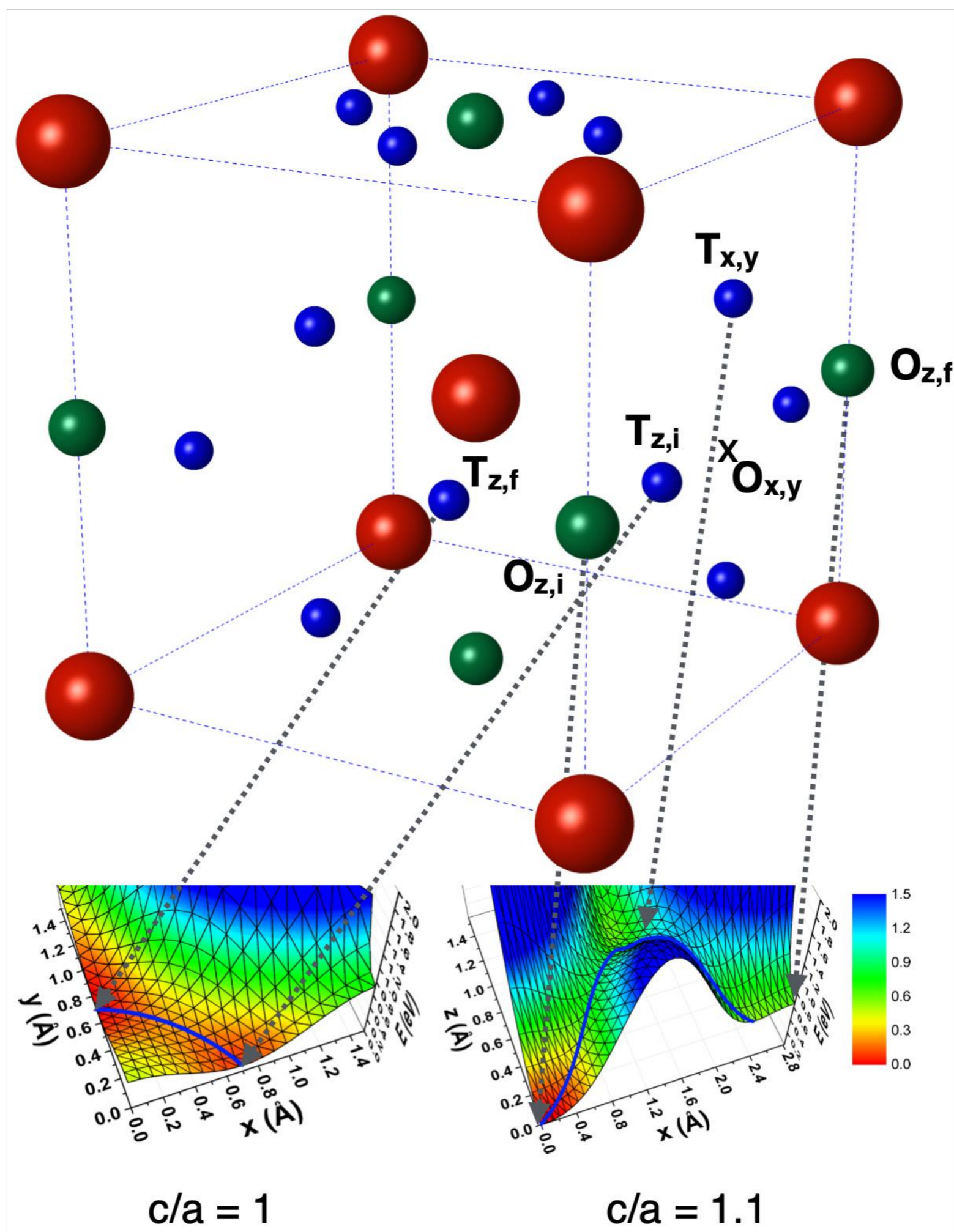
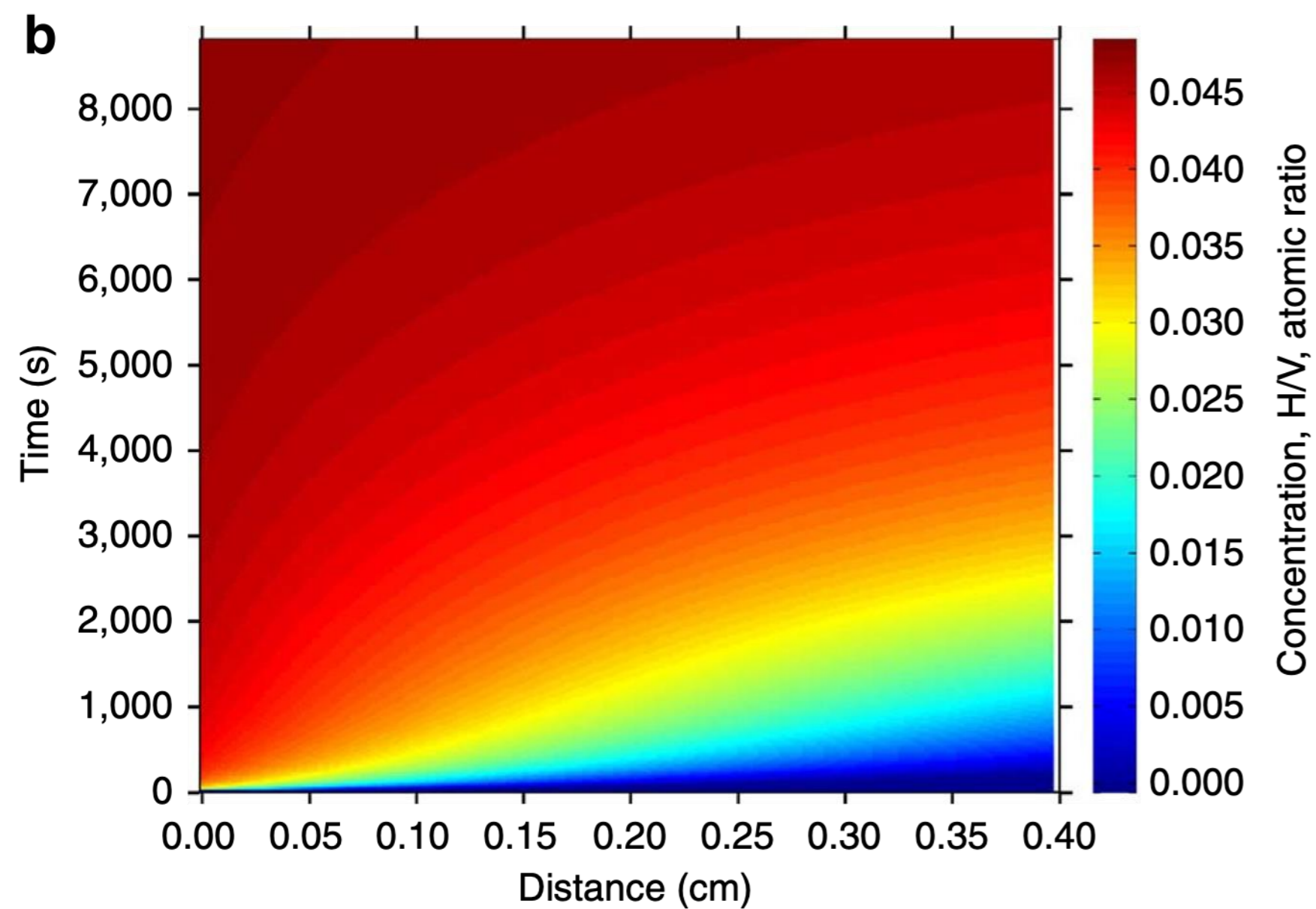
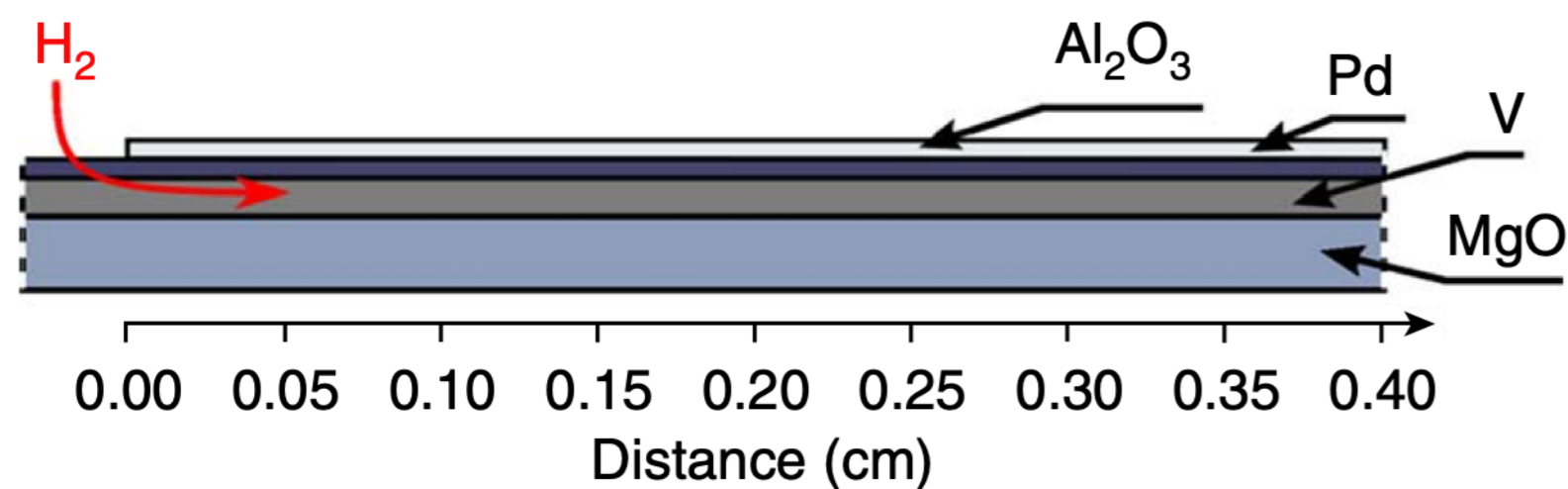

21 ML of vanadium

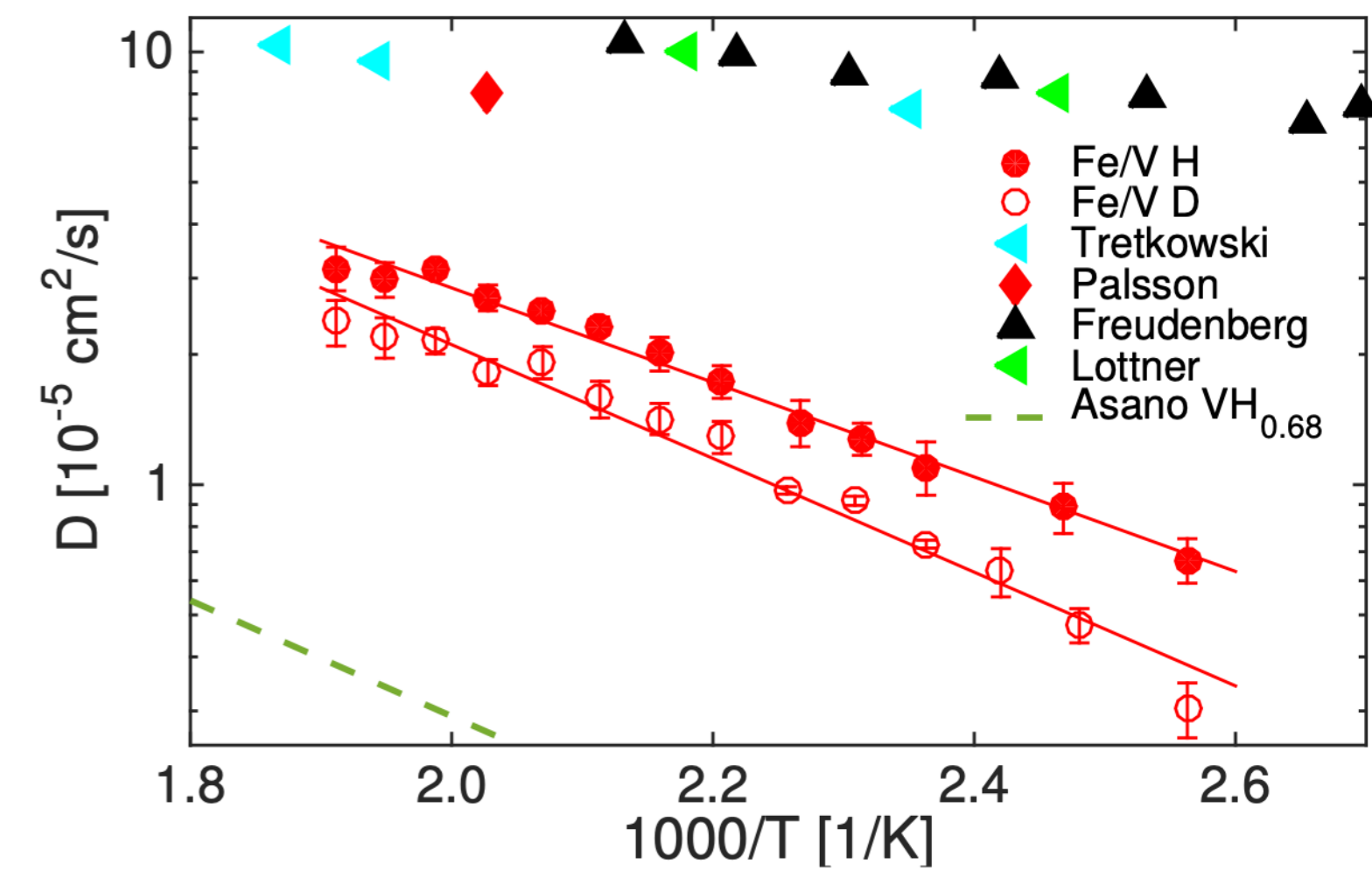

H diffusion measured with neutrons

J. Phys. Chem. Solids Pergamon Press 1971. Vol. 32, pp. 41–54. Printed in Great Britain.

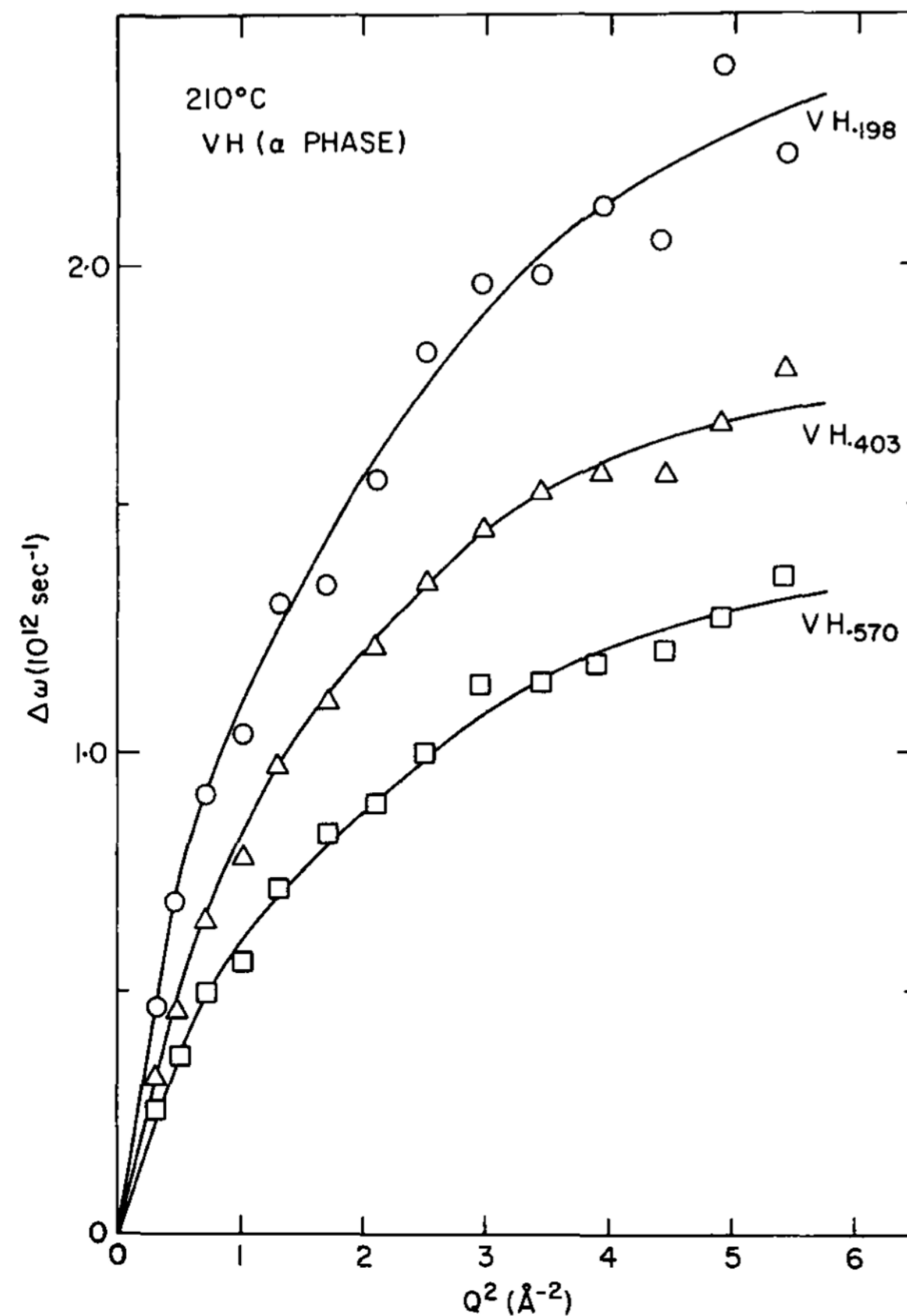

QUASIELASTIC NEUTRON SCATTERING BY HYDROGEN IN THE α AND β PHASES OF VANADIUM HYDRIDE*

J. M. ROWE, KURT SKÖLD† and H. E. FLOTOW
Argonne National Laboratory, Argonne, Ill. 60439, U.S.A.

and

J. J. RUSH

Center For Radiation Research, National Bureau of Standards, Washington, D.C. 20234, U.S.A.

(Received 8 January 1970; in revised form 6 April 1970)

Resonant enhancement

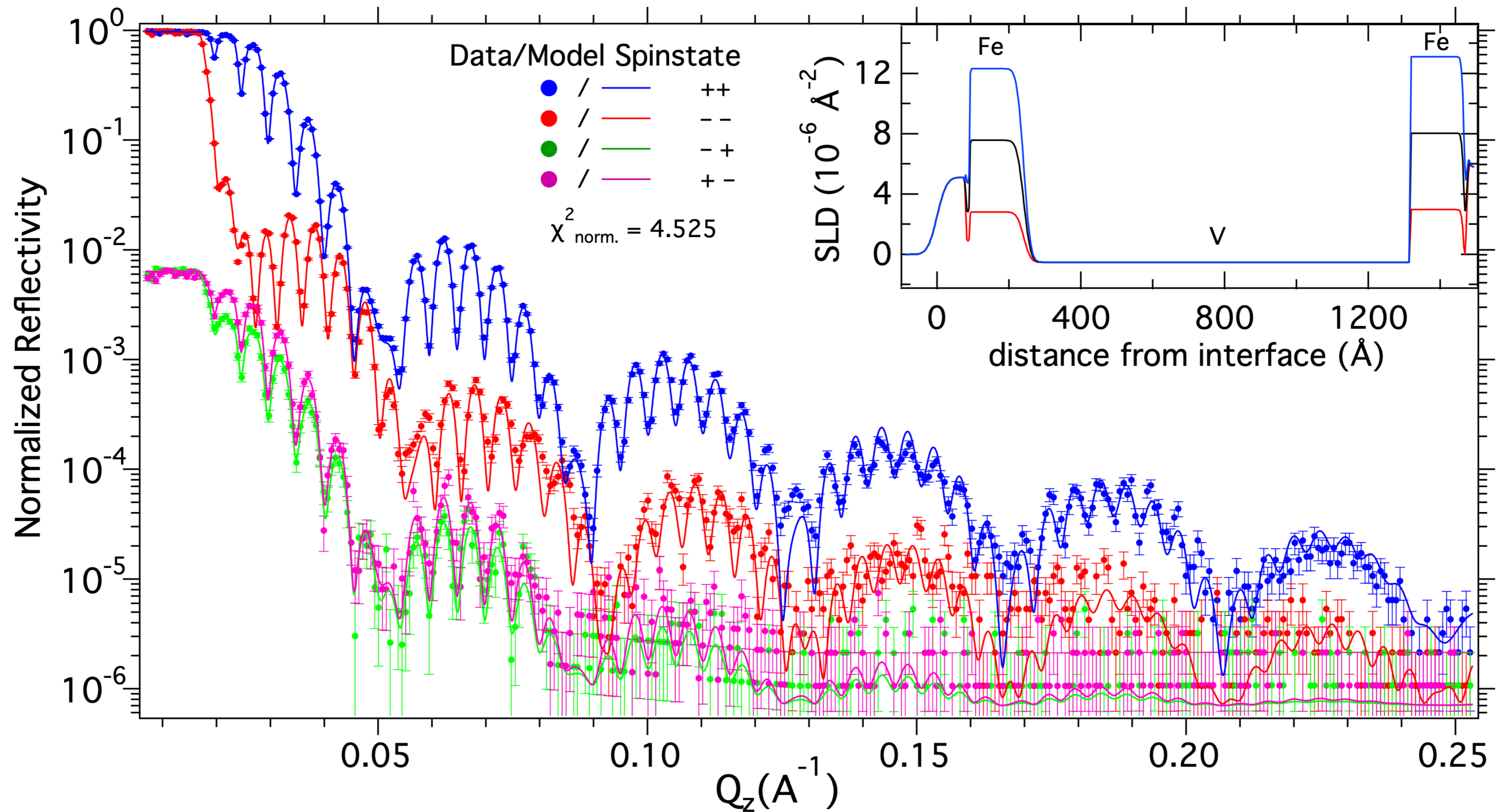

Calculating the wave field

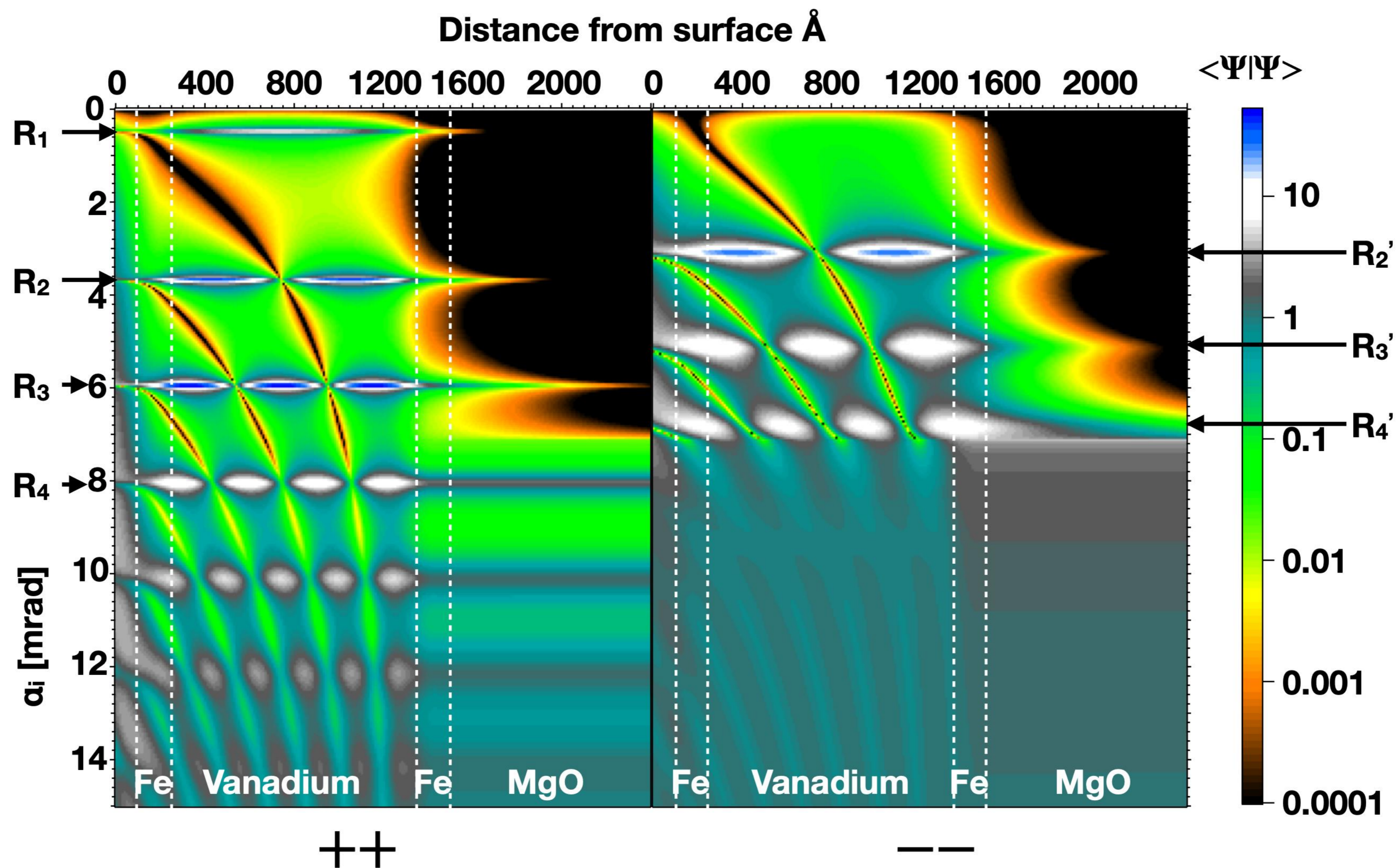

Incoherent scattering

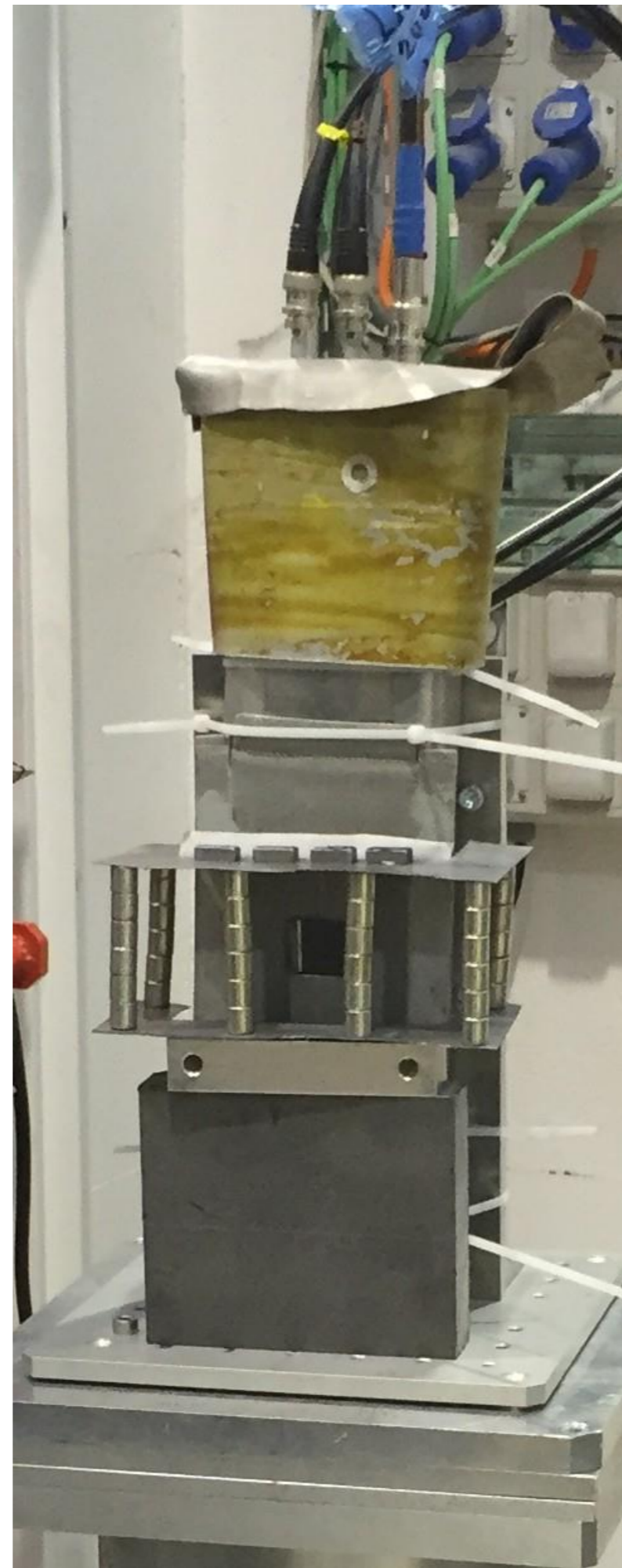

Incoherent scattering

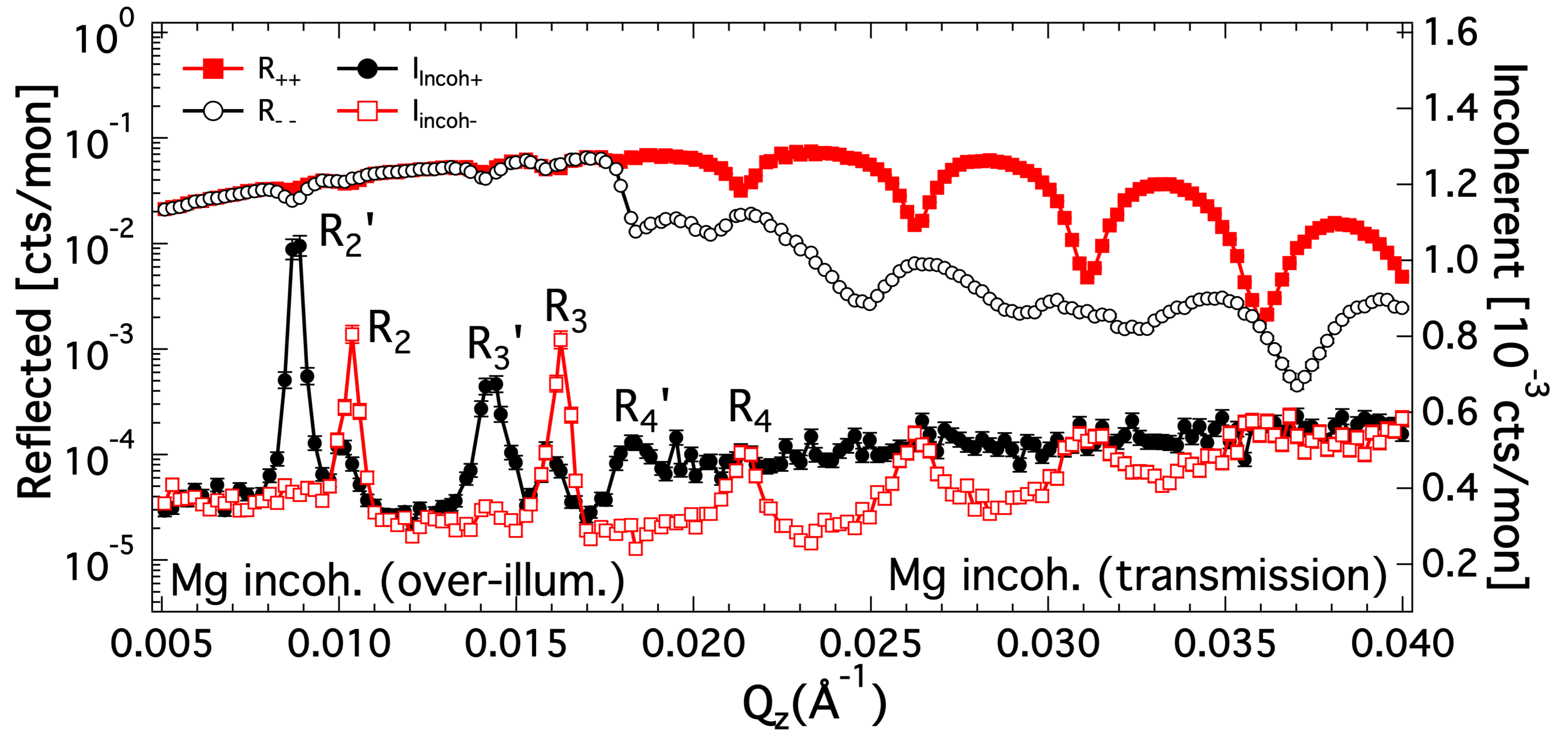

Hydrogen loading

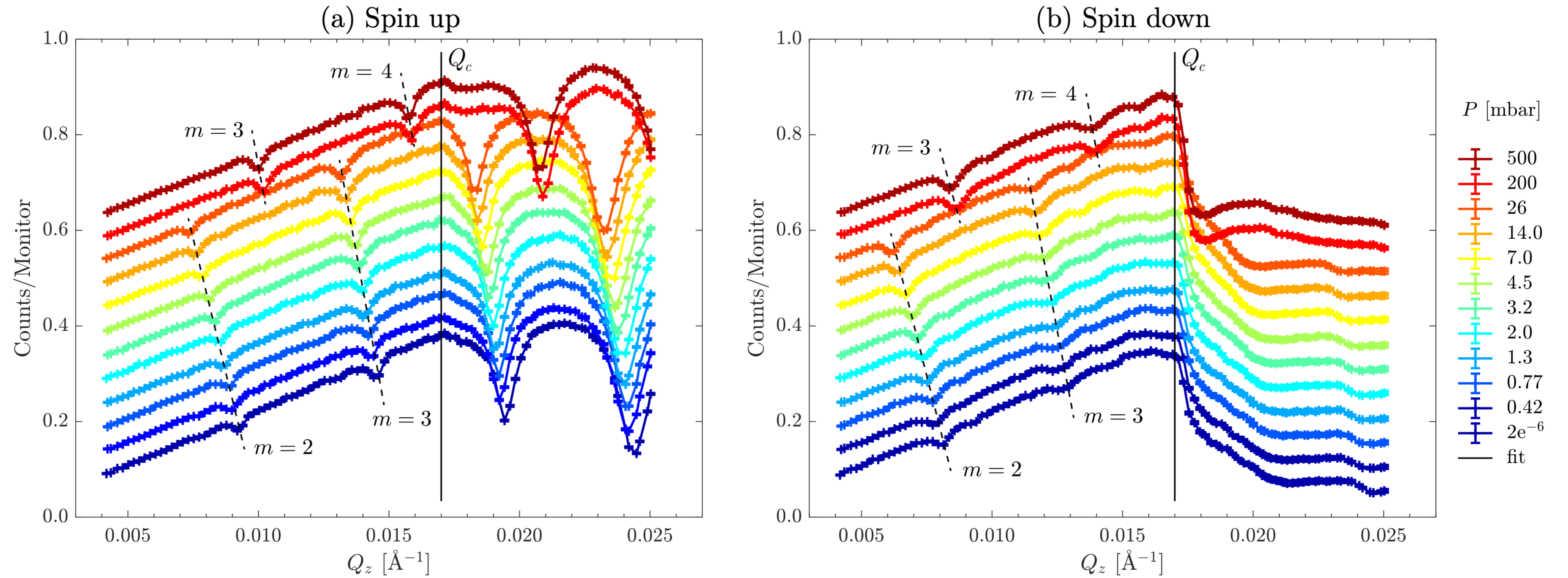

Summary

Hydrogen economy

Transition metal hydrides

Proximity effect

Finite size effect

Strain effect

Resistivity as a measure for order

Optical transmission as a measure for hydrogen concentration

Ion beam analysis as real space method

Neutron reflectometry

Swedish Neutron Week 2026



We are happy to announce that the **Swedish Neutron Week 2026** will take place at the conference venue on the AstraZeneca Gothenburg site, which is kindly offered by AstraZeneca for the conference free of charge. The conference will be jointly organised by SNSS and Swedness. It is scheduled to take place between **25 - 27 May**. A preliminary program is now available, including a diverse schedule including talks and posters on Quantum materials, Soft matter, Life science, Energy materials, neutron instrumentation and more. The Swedish Neutron Week has in the past served as an excellent forum for the neutron scattering community in the country and we hope to see as many of you as possible there. Abstract submission is now open until 29 March 2026 and registration, free of charge, is also open until 30 April 2026. The conference will also be succeeded by the Swedness 10th anniversary workshop on the 28-29 May also in Göteborg.

Sponsors



SWEDISH
NEUTRON
SCATTERING
SOCIETY



STIFTELSEN för
STRATEGISK FORSKNING



NEUTRONS
FOR SOCIETY



Vetenskapsrådet



Detektoren für Neutronen GmbH

Center for Neutron Scattering
Uppsala Universitet



RESEARCH USING
LARGE-SCALE
EXPERIMENTAL
FACILITIES

SuperADAM