

Pandemonium Free Data for Reactor Applications

Alejandro Algora

IFIC (CSIC-Univ. Valencia, Valencia), Spain

for the Valencia-Nantes-Jyväskylä-Surrey-Warsaw

et al. collaboration

Fission process and beta decay: close interconnection

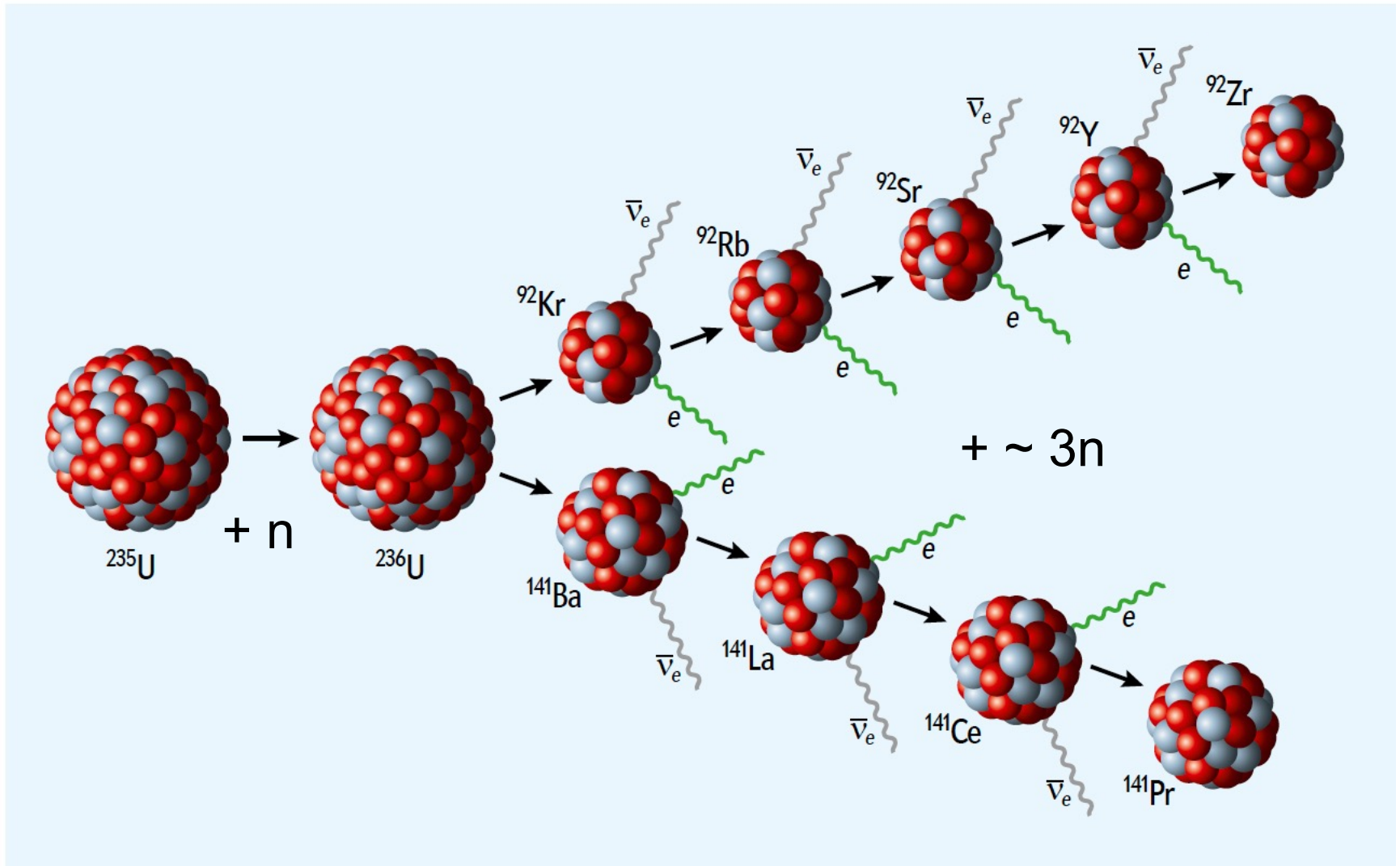

Every fission is approximately followed by 6 beta decays (sizable amount of energy)
Reactors are the largest (manmade) pacific sources of neutrinos. Produces 2×10^{20} v/s

1. Question

Data needed for describing properly a beta decay

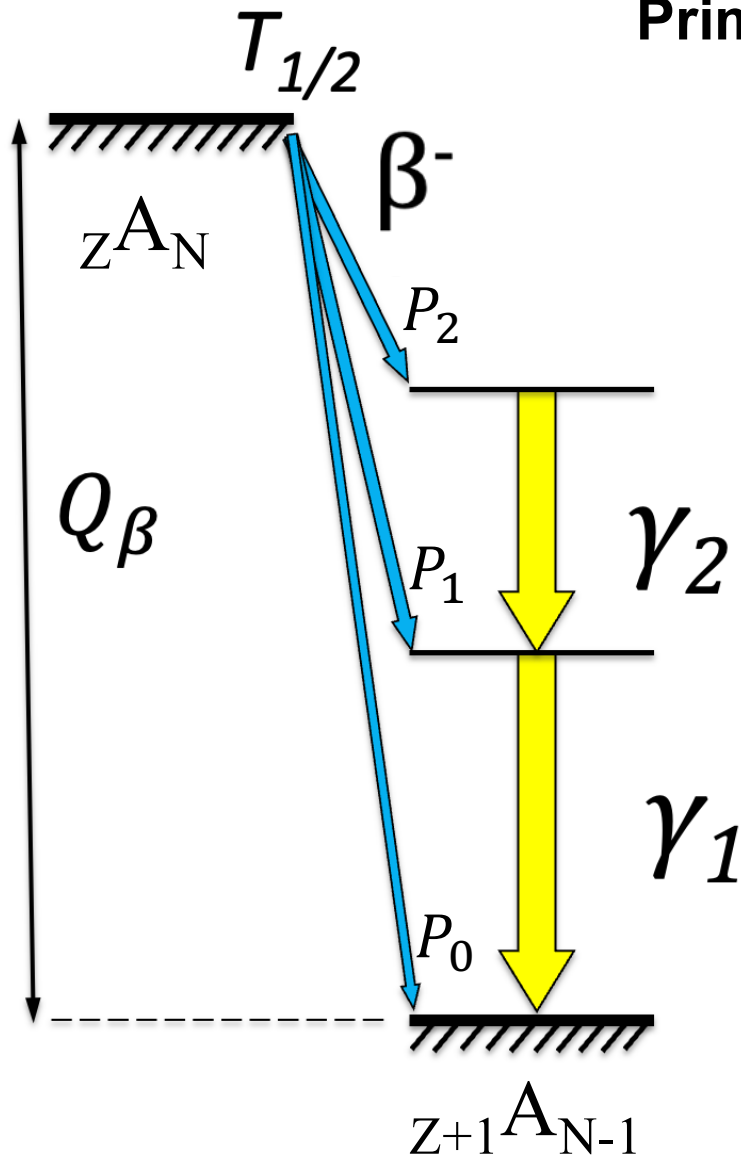

Primary experimental information needed

- Decay half-life
- Involved masses (Q values)
- Beta decay probabilities (feedings)

$$T_{1/2}, Q, I_{\beta,i} \equiv P_i * 100$$

$$t_i = \frac{T_{1/2}}{P_i} \quad (\text{partial half-life})$$

$$f = C \int_0^{p_{max}} F(Z', p) p^2 (Q - E_e)^2$$

$$f t_i \quad (\text{or } \text{Log } f t_i)$$

The problem of measuring the β -feedings ($I_{\beta} = P_{\beta} * 100$)

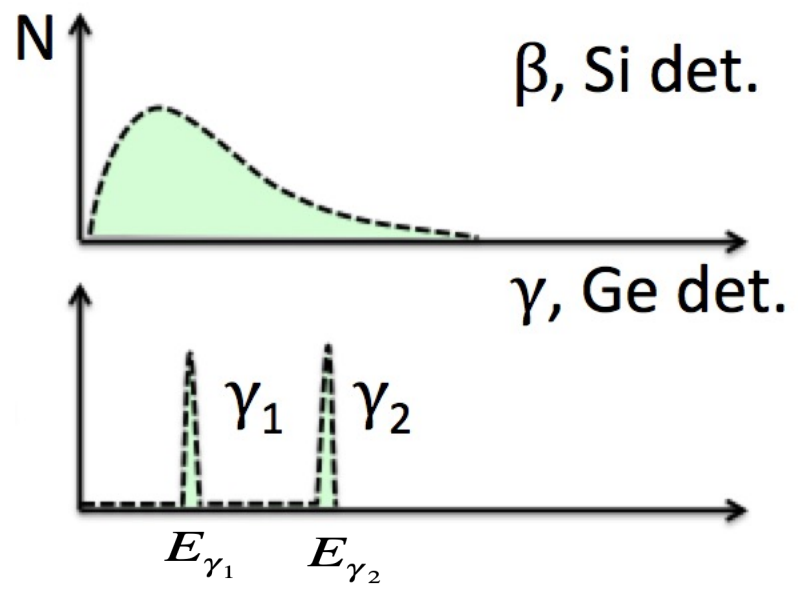
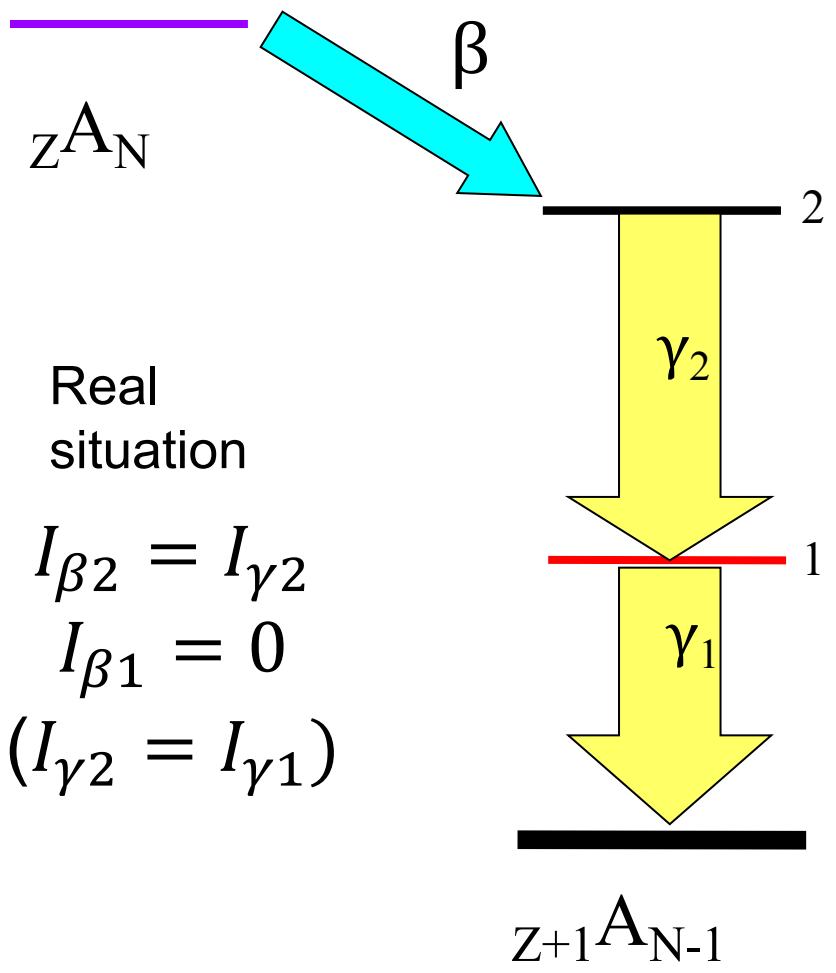

- Ge detectors are conventionally used to construct the level scheme populated in the decay
- From the γ intensity balance we deduce the β -feeding

The problem of measuring the β -feedings ($I_{\beta} = P_{\beta} * 100$)

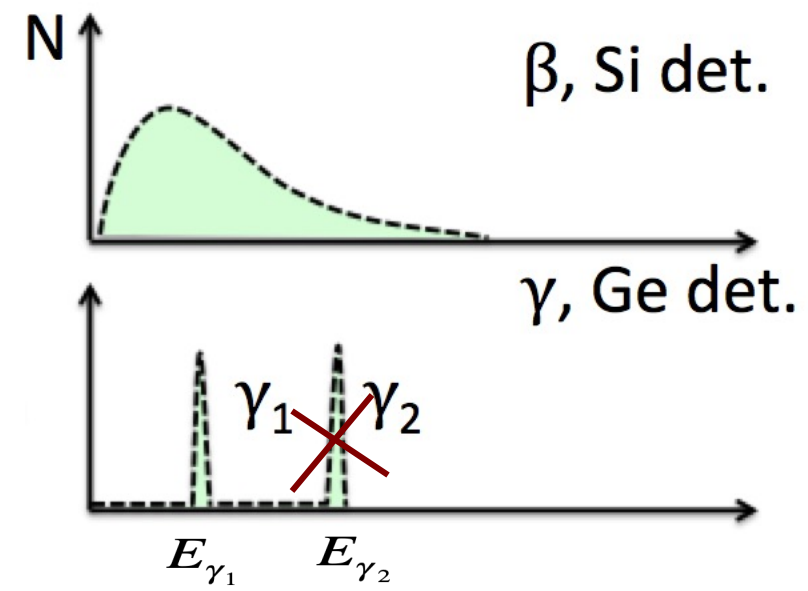
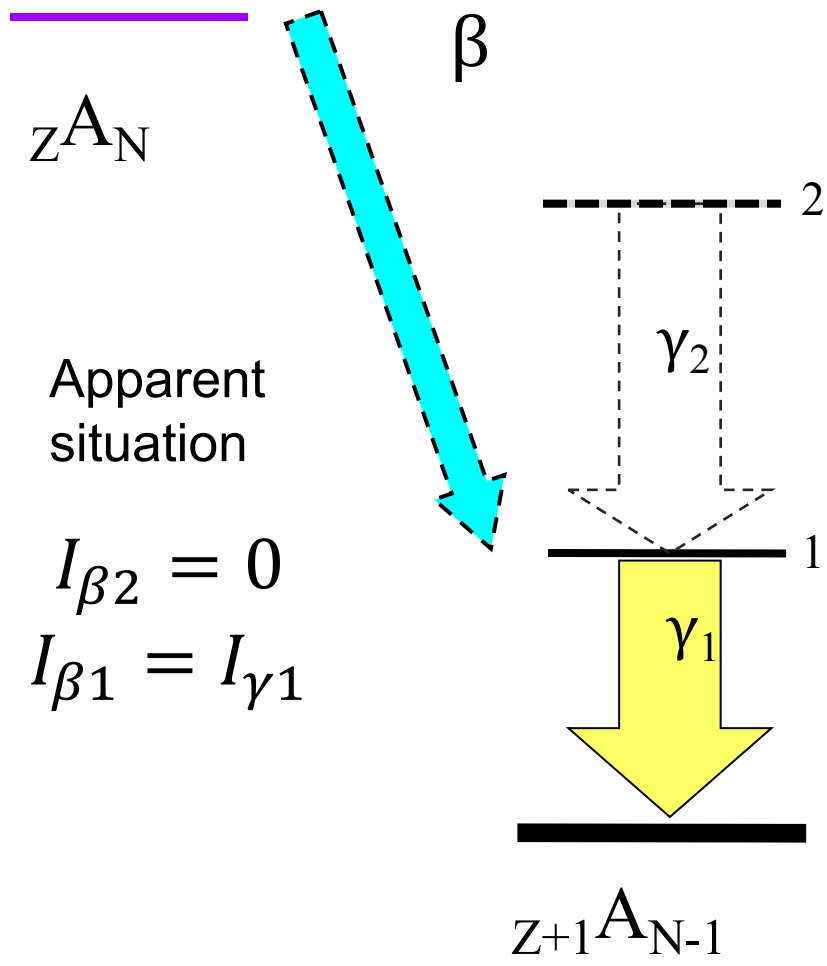

What happens if we miss some intensity?

Single $\gamma \sim \epsilon$

Coinc $\gamma_1 \gamma_2 \sim \epsilon_1 \epsilon_2$

Pandemonium effect (gamma version)

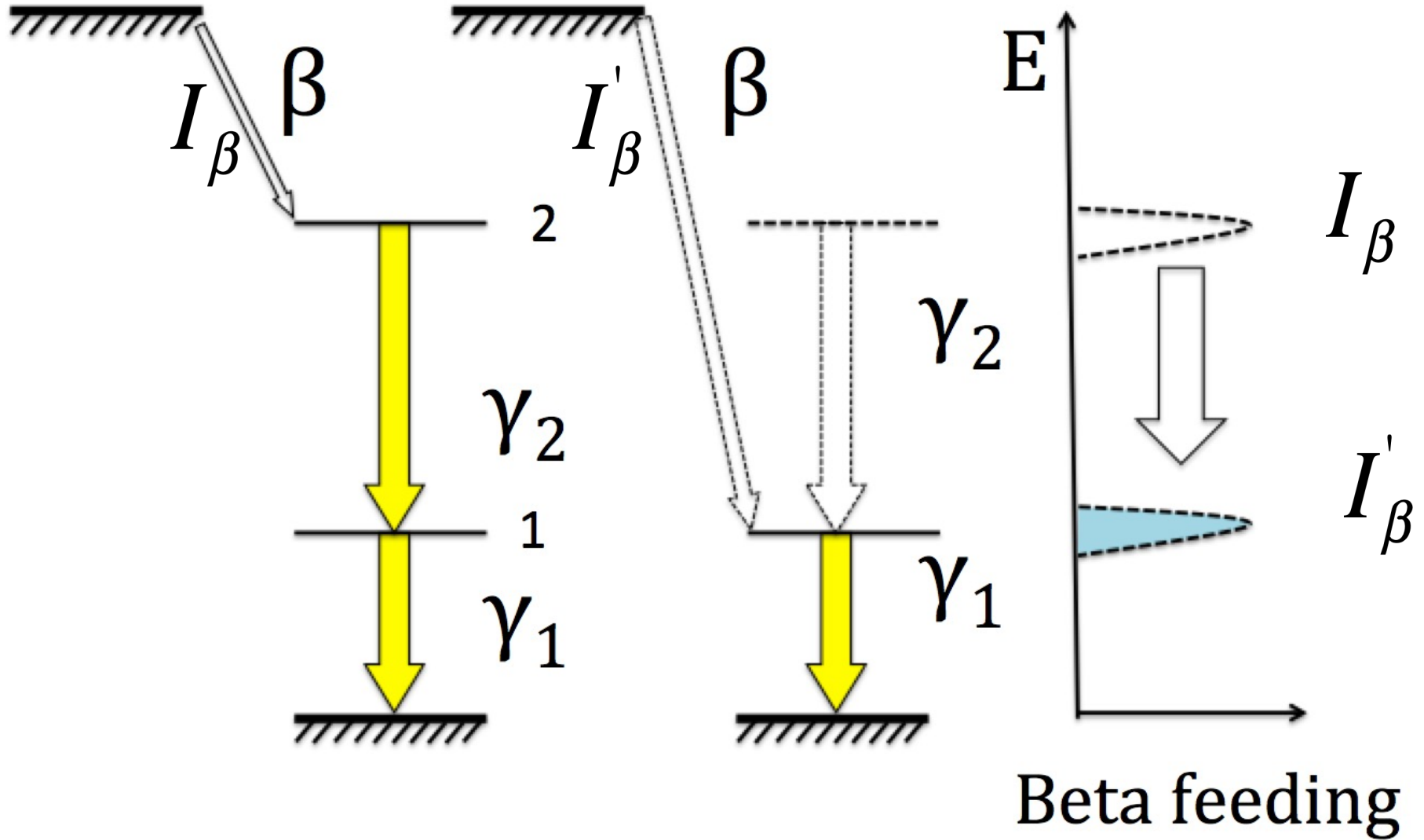

Pandemonium (The Capital of Hell)

introduced by John Milton (XVII) in his epic poem Paradise Lost



Painting by John Martin (~ 1825), presently at Louvre

Decay heat summation calculations: Why feedings are needed?

DATA bases:
feeding or beta
decay prob.
distributions

$$f(t) = \sum_i \mathcal{E}_i \lambda_i N_i(t)$$

Beta spectrum for a
beta transition
(to a defined level)

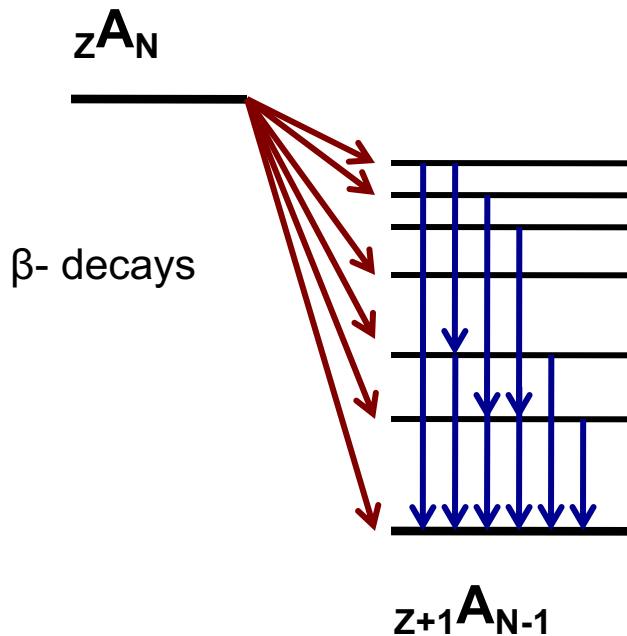

Key ingredient:
beta feedings

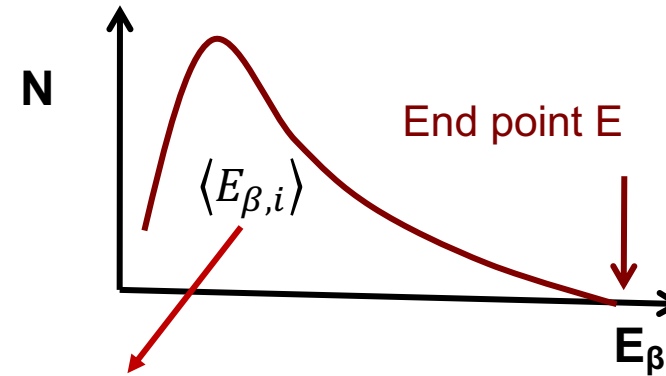

$$\bar{E}_\beta = \sum_i I_\beta(E_i) \langle E_{\beta,i} \rangle$$

$$\bar{E}_\gamma = \sum_i I_\beta(E_i) E_i$$

(Simplified way of calculation)

Effect of Pandemonium on summation calculations (decay heat example)

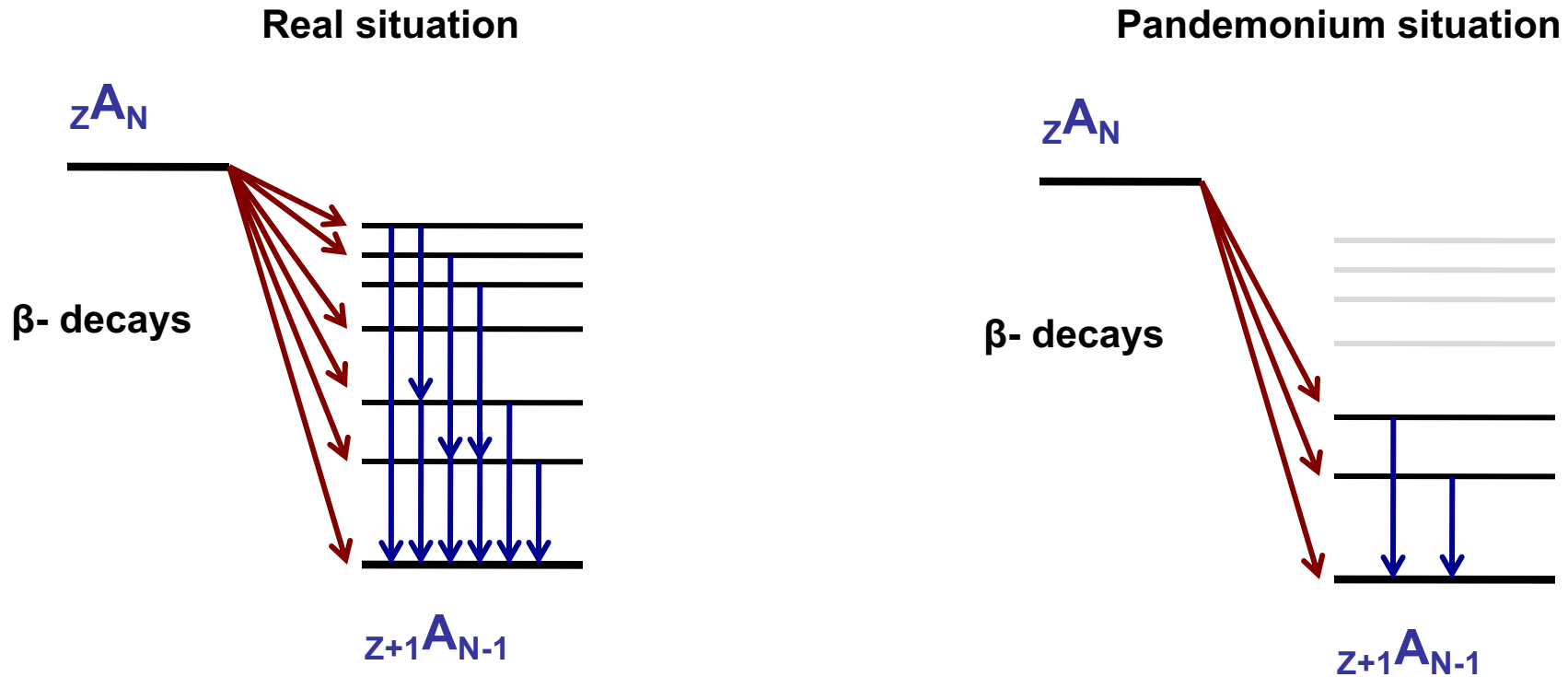

As a result of the Pandemonium, betas are estimated with higher energies from databases. Their spectra is harder. Incomplete level schemes can affect the antineutrino calculations as well.

The gamma mean energies are reduced since you detect less gammas.

This is why you should avoid using data suspicious of suffering from Pandemonium

Is summation a feasible alternative for antineutrino spectrum calculations?

Remember the decay heat summation calculation formula

$$f(t) = \sum_i E_i \lambda_i N_i(t)$$

Beta decay (β^-)

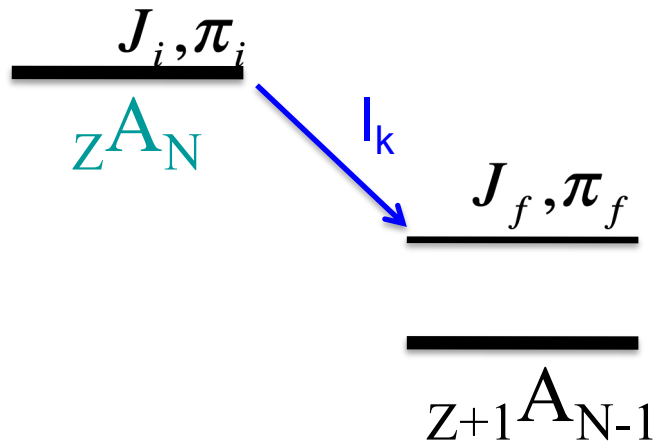

Spectrum shape for each transition

$$J_i, \pi_i \rightarrow J_f, \pi_f$$

$$S(Q - E_k, J_i \pi_i, J_f \pi_f)$$

Spectrum for decay (n)

$$S_n(E) = \sum_k I_k S(Q - E_k, J_i \pi_i, J_f \pi_f)$$

Beta Branch, or feedings

$$S(E) = \sum_n \lambda_n N_n S_n(E) / r = \sum_n CFY_n S_n(E)$$

Anti-neutrino rate per fission (Vogel, 1981)

Determination of the primary antineutrino spectrum (1980s): conversion method

- **“Pure conversion procedure”**: using the cumulative beta spectrum measured by Schreckenbach et al. from different fissile nuclides (^{235}U , $^{239,241}\text{Pu}$) at ILL and more recently ^{238}U (Haag et al.), which requires complex conversion procedures and assumptions (virtual beta branches, etc.)

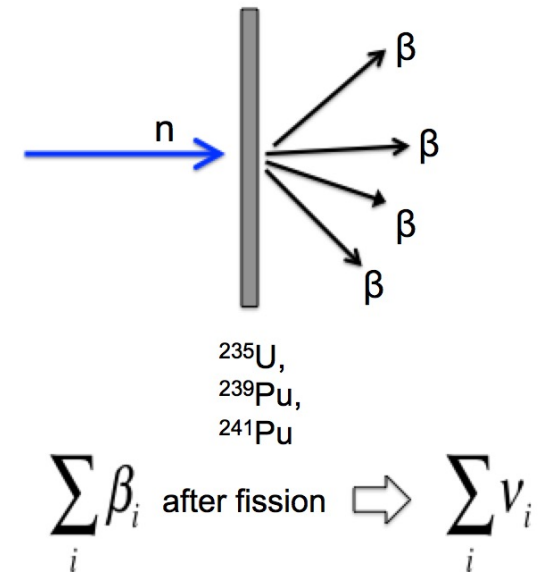
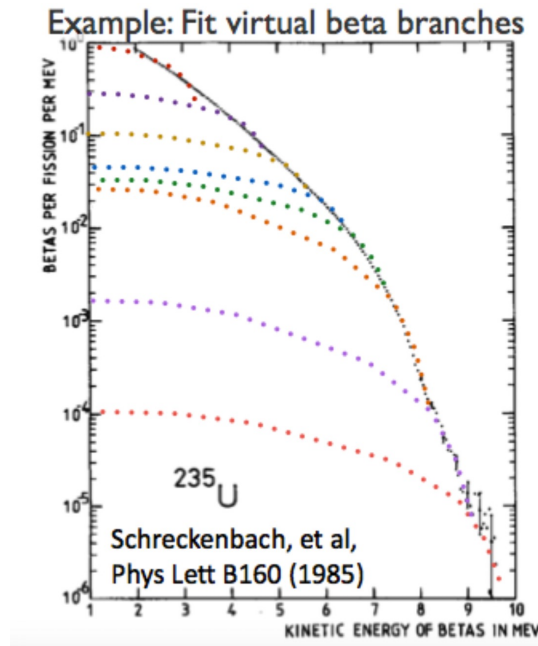
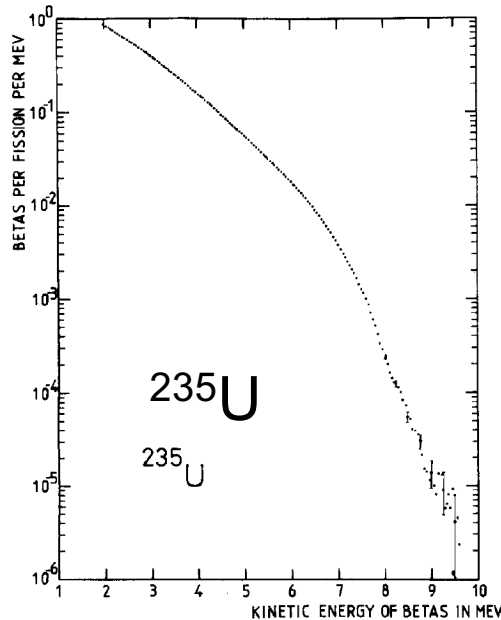

$$N_{\beta}(E) = \sum_i a_i \times g'_i(E, E_0^{(i)}) \times P_i \left[E, E_0^{(i)} \bar{Z}(E_0^{(i)}) \right]$$

30 hypothetical beta branches,
End point distribution $\{a_i, E_0^{(i)}\}$, P_i
shapes, $\bar{Z}(E_0^{(i)})$, g'_i rad. correction

Modern ways (2011): The Huber Model, updated conversion method

Starting point: conversion from the data of Schreckenbach applying all “possible” corrections to the beta spectrum and updated information from nuclear databases

Corrections used: finite size, screening, radiative corrections, weak magnetism

Estimation of uncertainties related to the different theoretical corrections of the beta spectrum and with the conversion algorithm. Largest source of uncertainty is associated with the weak magnetism.

The deduced antineutrino spectrum from the fitted beta spectrum shows an increase of 3% in the antineutrino flux, confirming Mueller results. Their predicted spectrum agrees within uncertainties.

P. Huber, Phys. Rev. C 84, 024617 (2011)

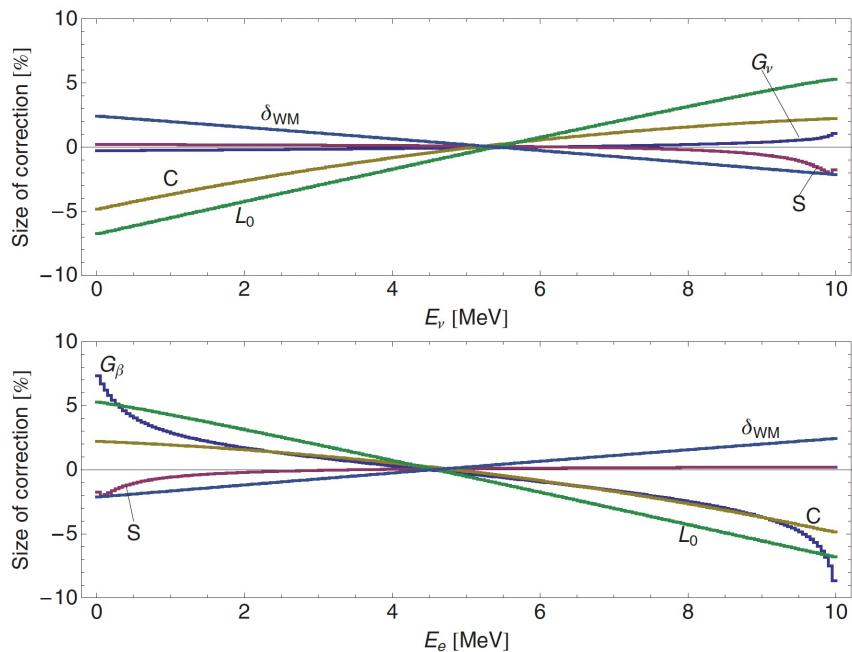

FIG. 1. (Color online) Relative size of the various corrections listed in Eq. (4) for a hypothetical β decay with $Z = 46$, $A = 117$, and $E_0 = 10$ MeV. The top panel shows the effect on the neutrino spectrum, whereas the bottom panel shows the effect on the β spectrum.

Modern ways (2011):

The Mueller Hybrid Model, summation + conversion

Starting point: summation method, employing an updated database

Summation of all beta branches from all fission products predicted by an evolution code. Estimated uncertainties of the order of 10-20 % because of systematic errors and the incompleteness of the databases.

For the most relevant fissile nuclides ^{235}U , ^{239}Pu , ^{241}Pu they use the measured spectrum of Schreckenbach data to determine the “missing information” from databases.

They fit the residuals with a conversion procedure.

The deduced antineutrino spectrum from the fitted beta spectrum shows an increase of 3% in the antineutrino flux

Mueller et al., Phys. Rev C 83, 054615 (2011)

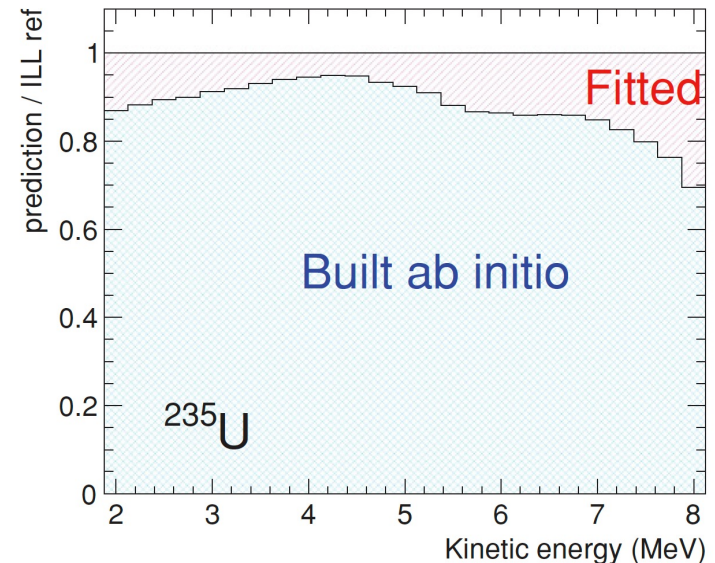
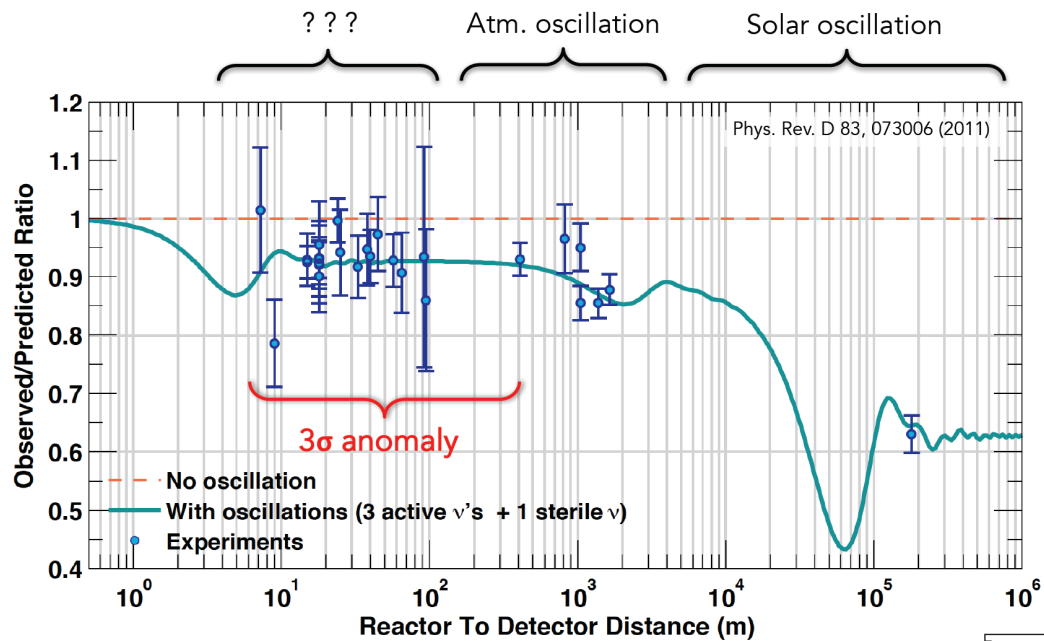

FIG. 5. (Color online) Lower (blue) double hatched area shows the contribution of our *ab initio* prediction (ENSDF + pandemonium corrected nuclei) relative to the ILL reference data. The missing contribution coming from unknown nuclei and remaining systematic effects of nuclear databases [upper (red) hatched area] is fitted using a set of five effective β branches.

Black clouds in the reactor antineutrino field



Reactor anomaly ?

Deficit in the number of antineutrinos detected in short base lines, compared with the predictions of the Huber-Muller model. It can be explained by the existence of a sterile neutrino.

Mention et al. PRD 83.073006

Spectrum distortion (~5 MeV)

RENO results, PRL 116, 211801 (2016)

also seen in DAYA BAY

Many possible explanations have

been discussed, from problems

with the measurements to problems

with the models (fission yields, problems with the meas. of Schreckenbach et al., etc.)

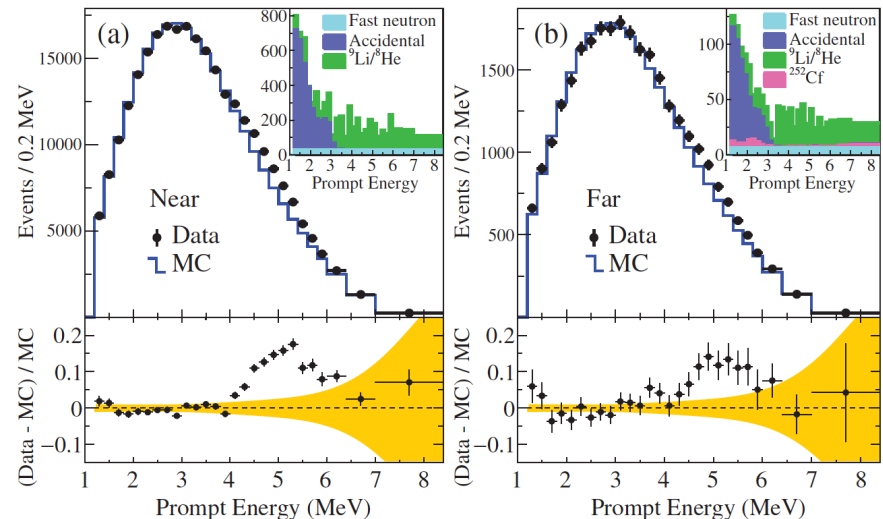

Total absorption gamma spectroscopy applied to beta decay studies

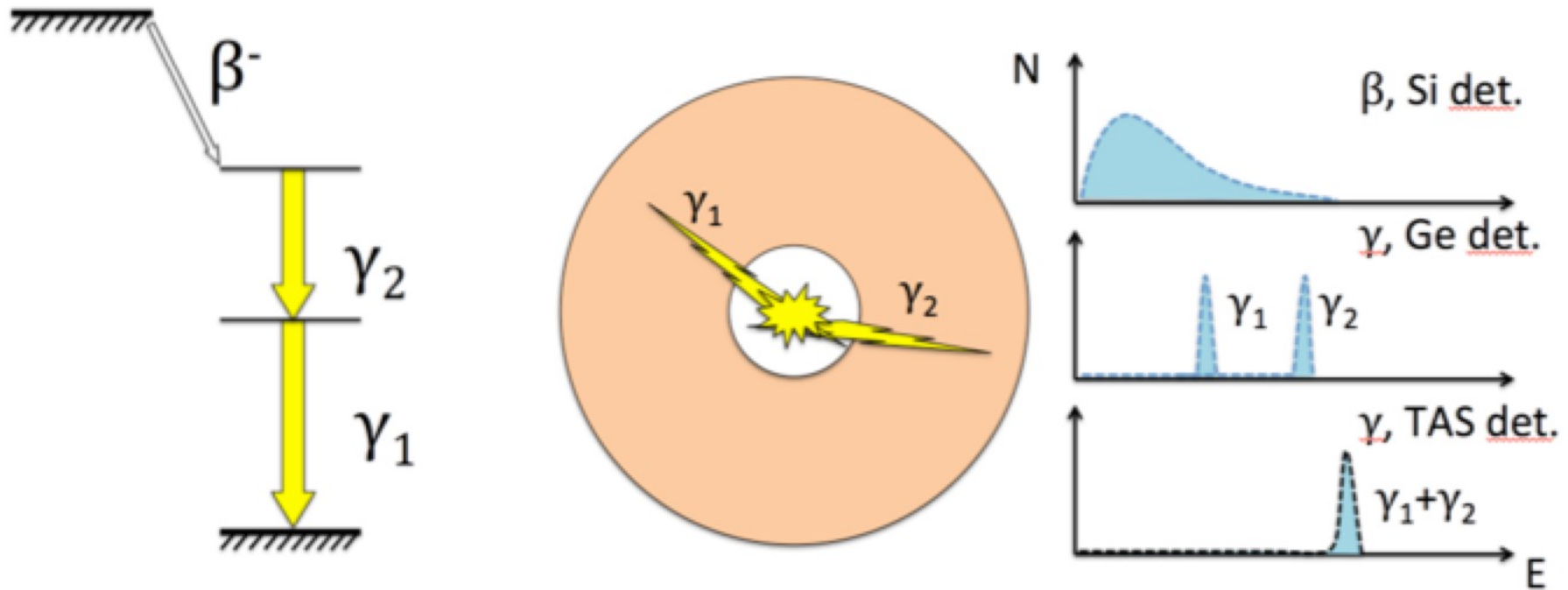

$$d = R(B) \cdot f$$

(note that $f \equiv I_\beta$)

Requirements: clean spectrum or a proper treatment of the contaminants, some knowledge of decay level scheme of the daughter, etc.

DTAS detector for DESPEC (FAIR)

16 + (2) modules:

15 x 15 x 25 cm³ **Nal(Tl)**

+ 5" PMT (50% light col.)

V= 95 L, M= 351 kg

Tot eff ~90%

**Fast ions active stopper: AIDA
(Stack of DSSSD)**

TAS++

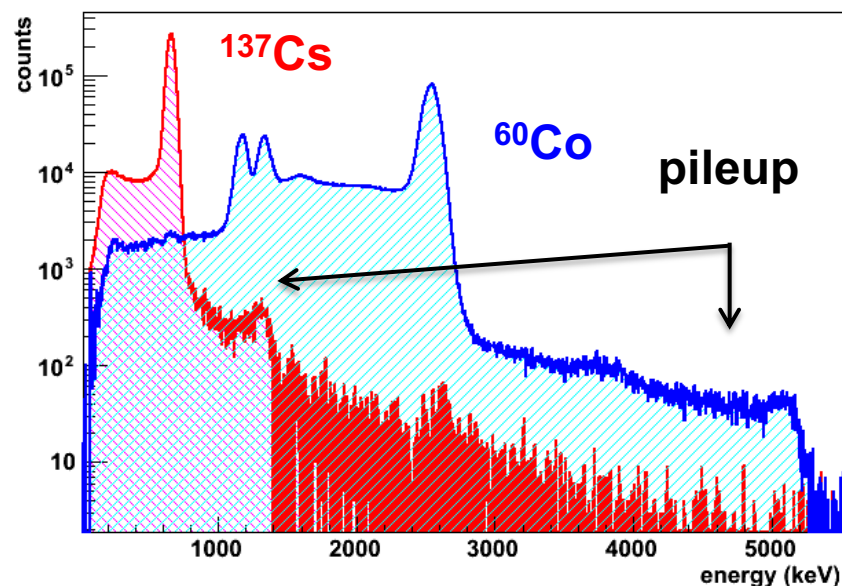
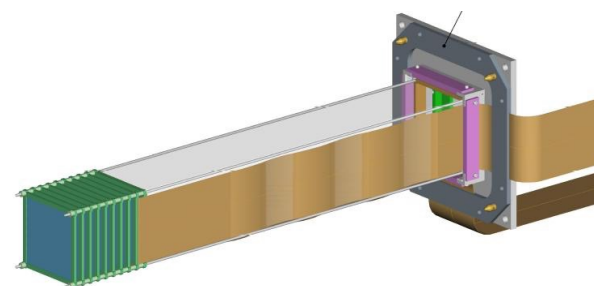
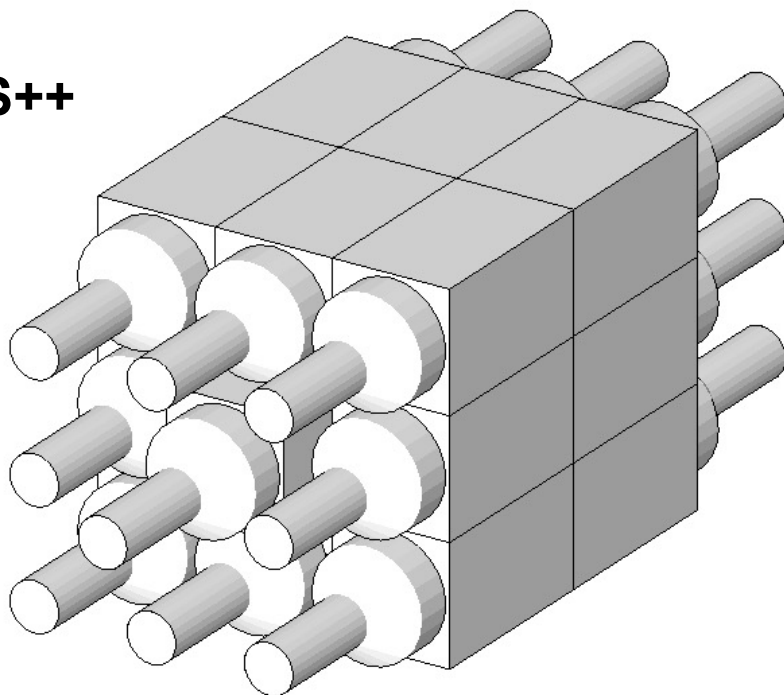

TDR approved (01/2013)

Commissioning at IFIC (01/2014)

First experiment at JYFL (02-03/2014),

used more recently at RIKEN, and at GSI

A flavour of real spectra

“Small” detectors

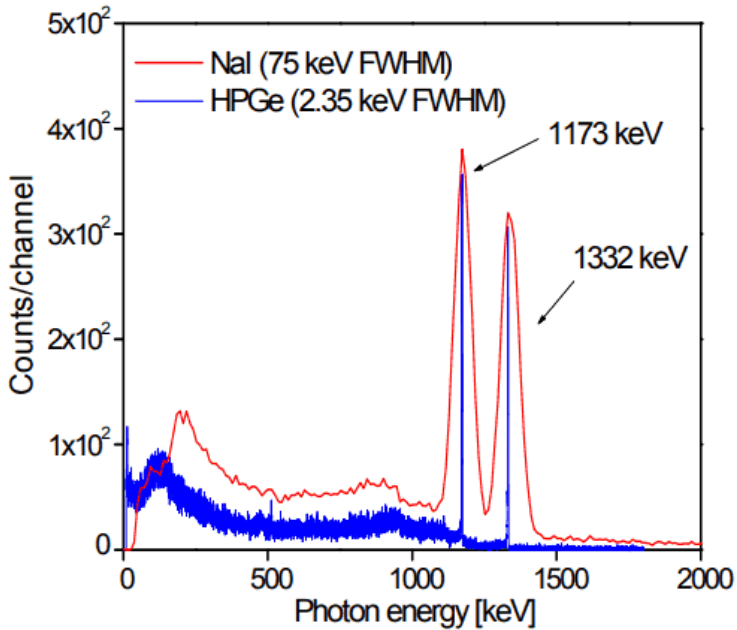

Real calorimeter detector

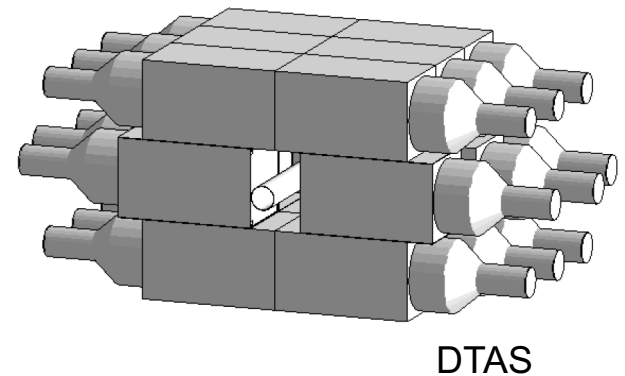
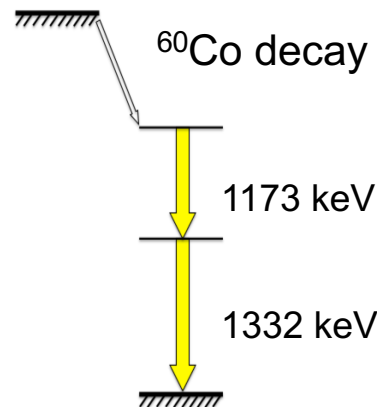
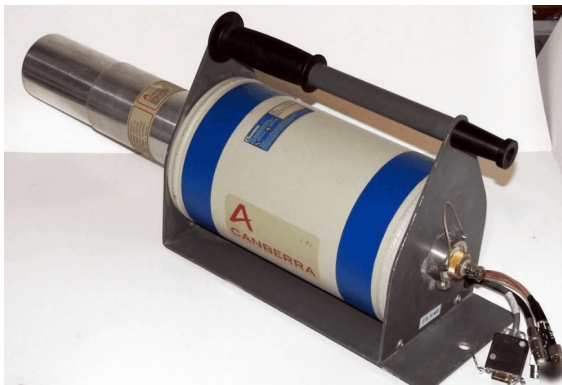
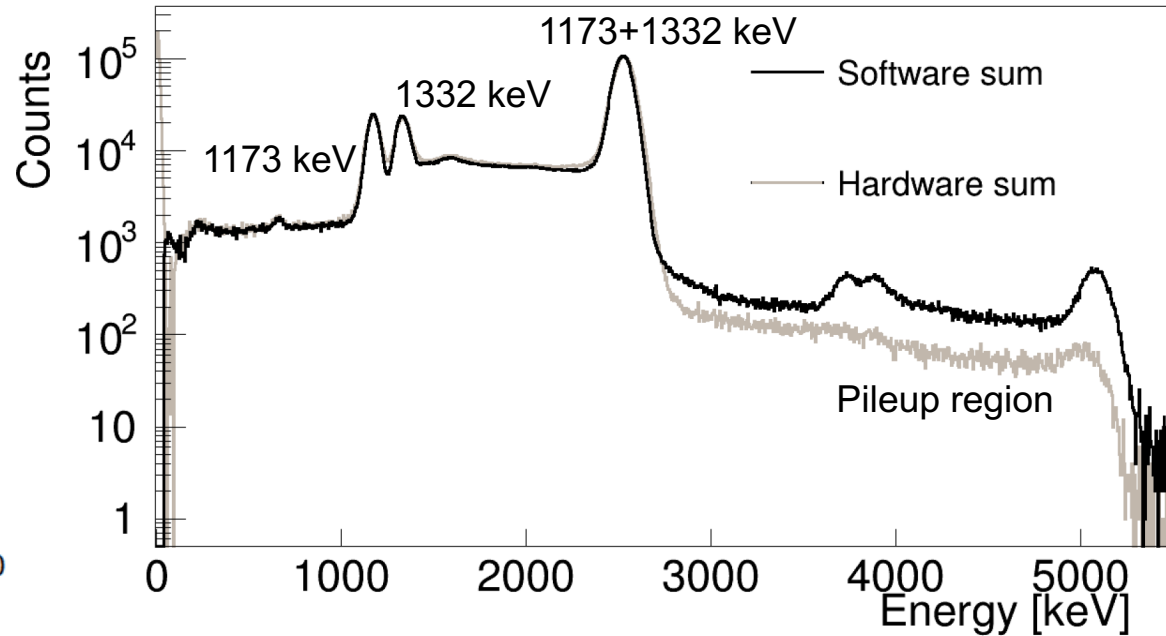

The complexity of the TAGS analysis: an ill posed/conditioned problem

$$d = R(B) \cdot f$$

Primary question: f determination
but there is an incomplete knowledge of the level scheme populated

Steps:

1. Define B (branching ratio matrix)
2. Calculate R(B) (MC sim.)
3. Solve the equation $d=R(B)f$ using an appropriate algorithm

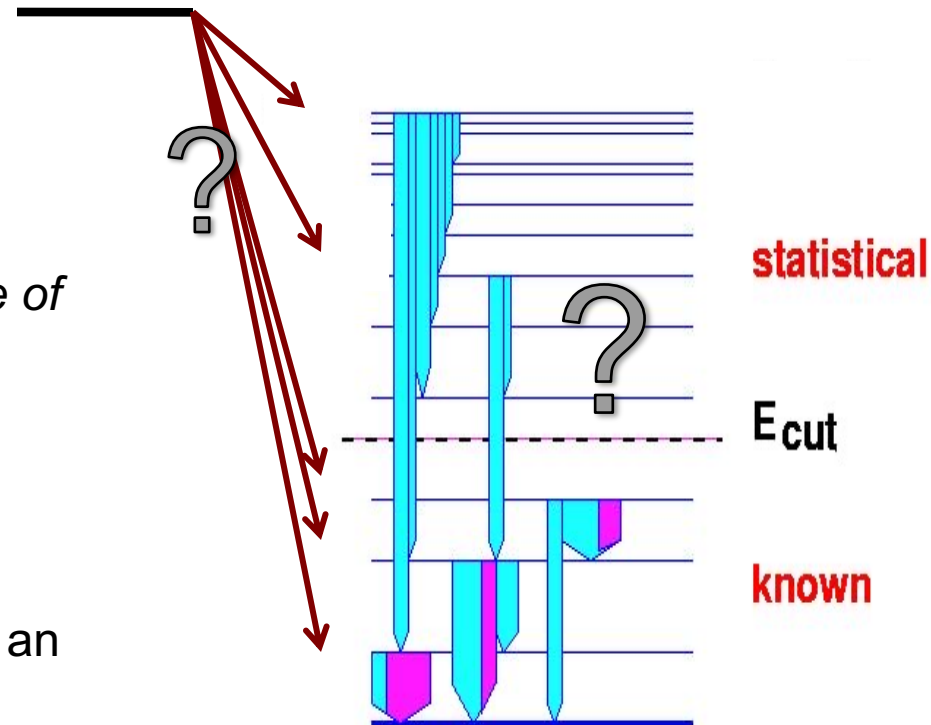

Expectation Maximization (EM) method:
modify knowledge on causes from effects

$$P(f_j | d_i) = \frac{P(d_i | f_j) P(f_j)}{\sum_j P(d_i | f_j) P(f_j)}$$

Algorithm:

$$f_j^{(s+1)} = \frac{1}{\sum_i R_{ij}} \sum_i \frac{R_{ij} f_j^{(s)} d_i}{\sum_k R_{ik} f_k^{(s)}}$$

Mathematical formalization by Tain, Cano, et al.

My first Pandemonium experience: ^{150}Ho 2⁻ isomer decay

1064 gamma rays, 295 levels
Algora, Rubio, et al. PRC68.034301

42 Ge capsules

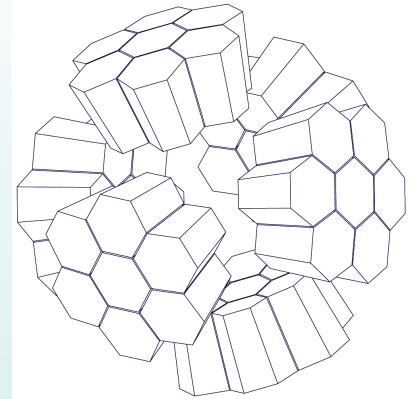

Cluster Cube
10% eff at Co

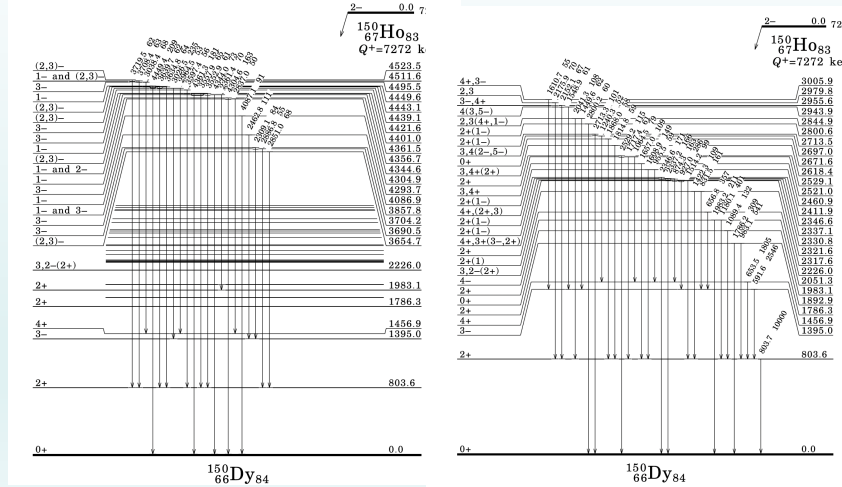

Guinness record ?

10 m level scheme
(1 gamma per cm)

Before 2003

Only **4 gamma**
rays known

D. Cano-Ott, J. L. Tain et al.

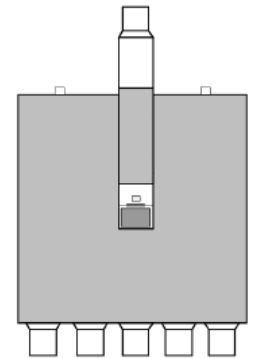
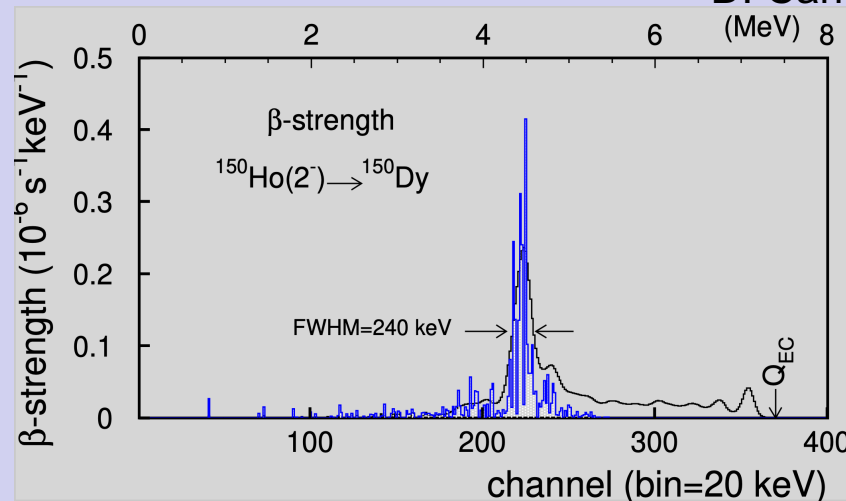

LBL TAS

The CC sees
approx. 50% of the
total TAS B(GT)

Why Univ. of Jyväskylä IGISOL facility?

Odd ISOL case: The ion guide technique

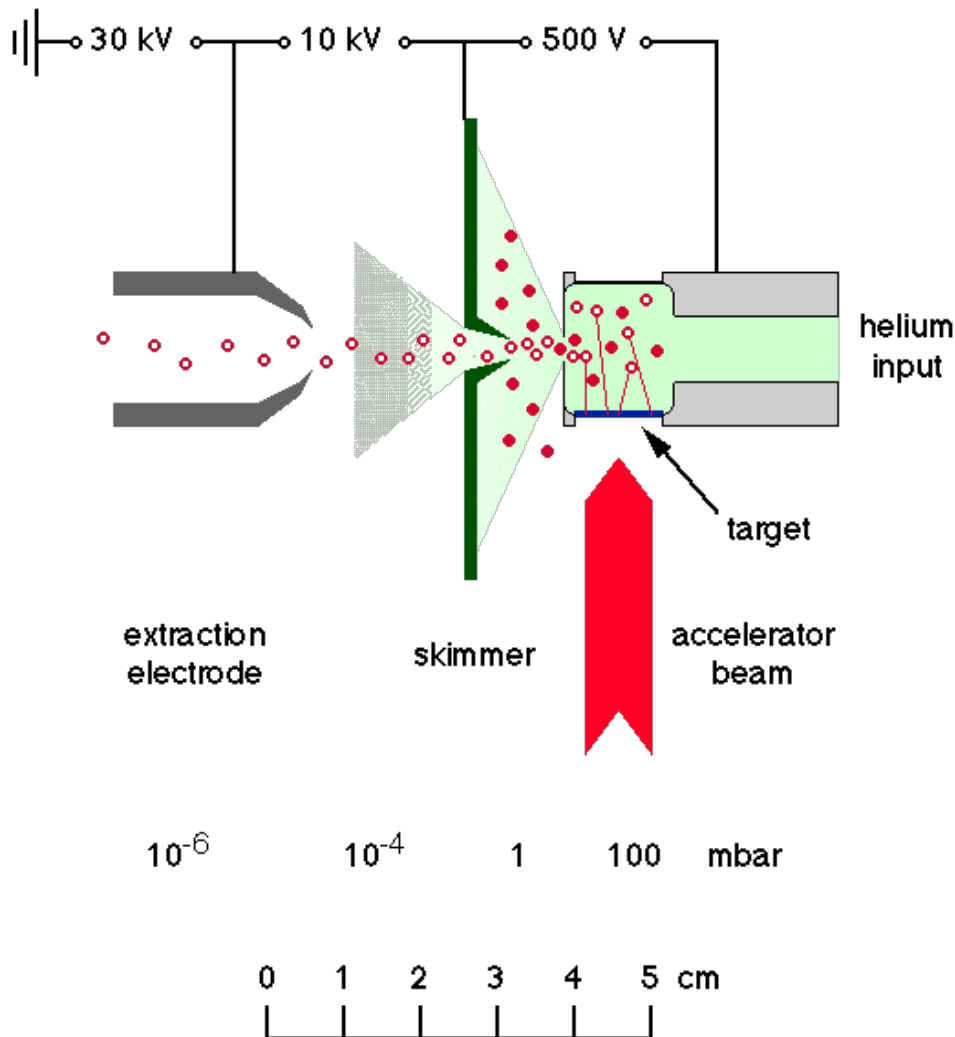

Generic ion guide: the nuclear reaction products are stopped in a gas and are transported through a differential pumping system into the accelerator stage of the mass separator.

The process is fast enough for the ions to survive as single charged ions. The system is chemically insensitive and very fast (sub-ms).

Why JYFL(IGISOL)?: ion guide technique + a bonus

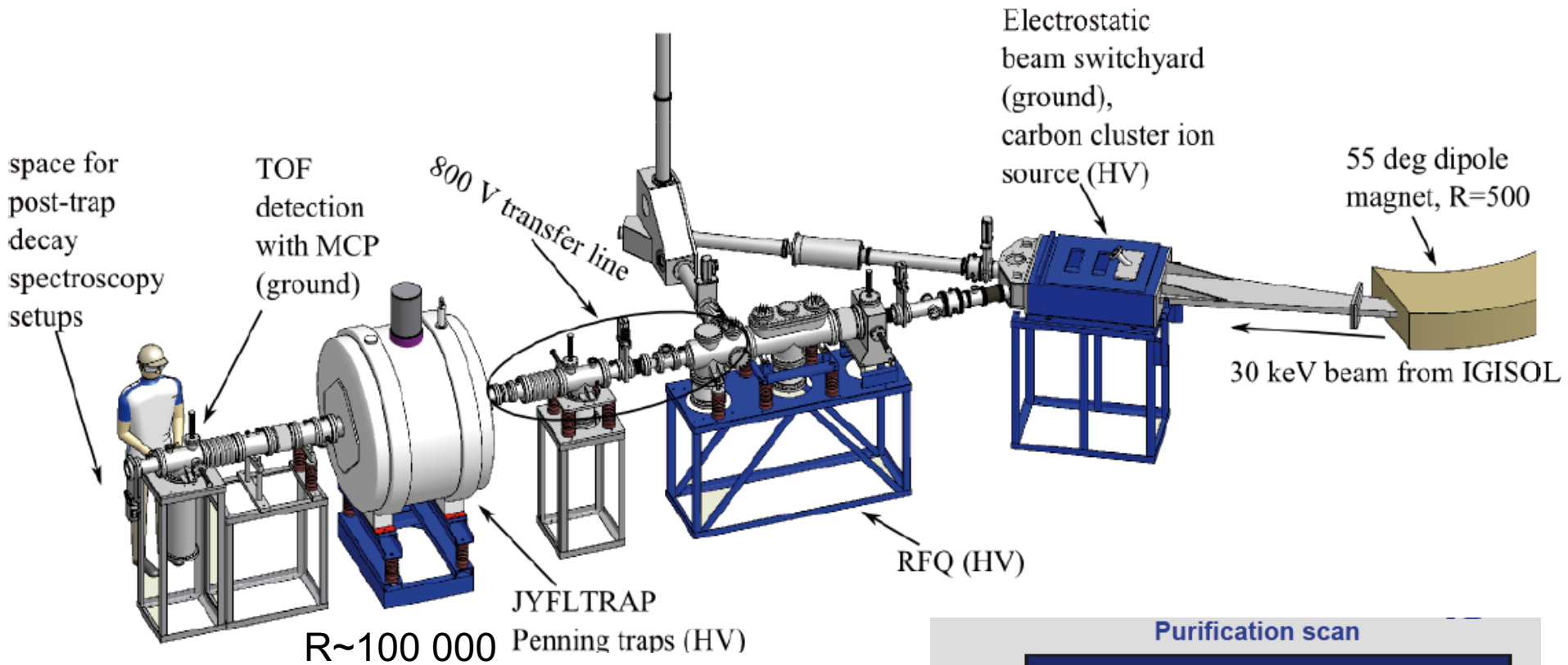

The main reasons are the chemical insensitivity (ion guide technique), high purity by means of purification of the beam using the JYFLTRAP and acceptable yields!

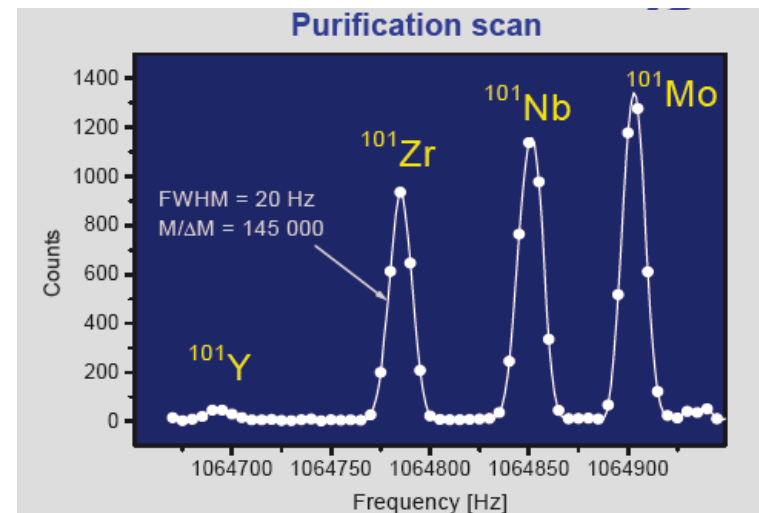

Impact of some of our earlier data:

$^{102,104,105,106,107}\text{Tc}$, ^{101}Nb , ^{105}Mo

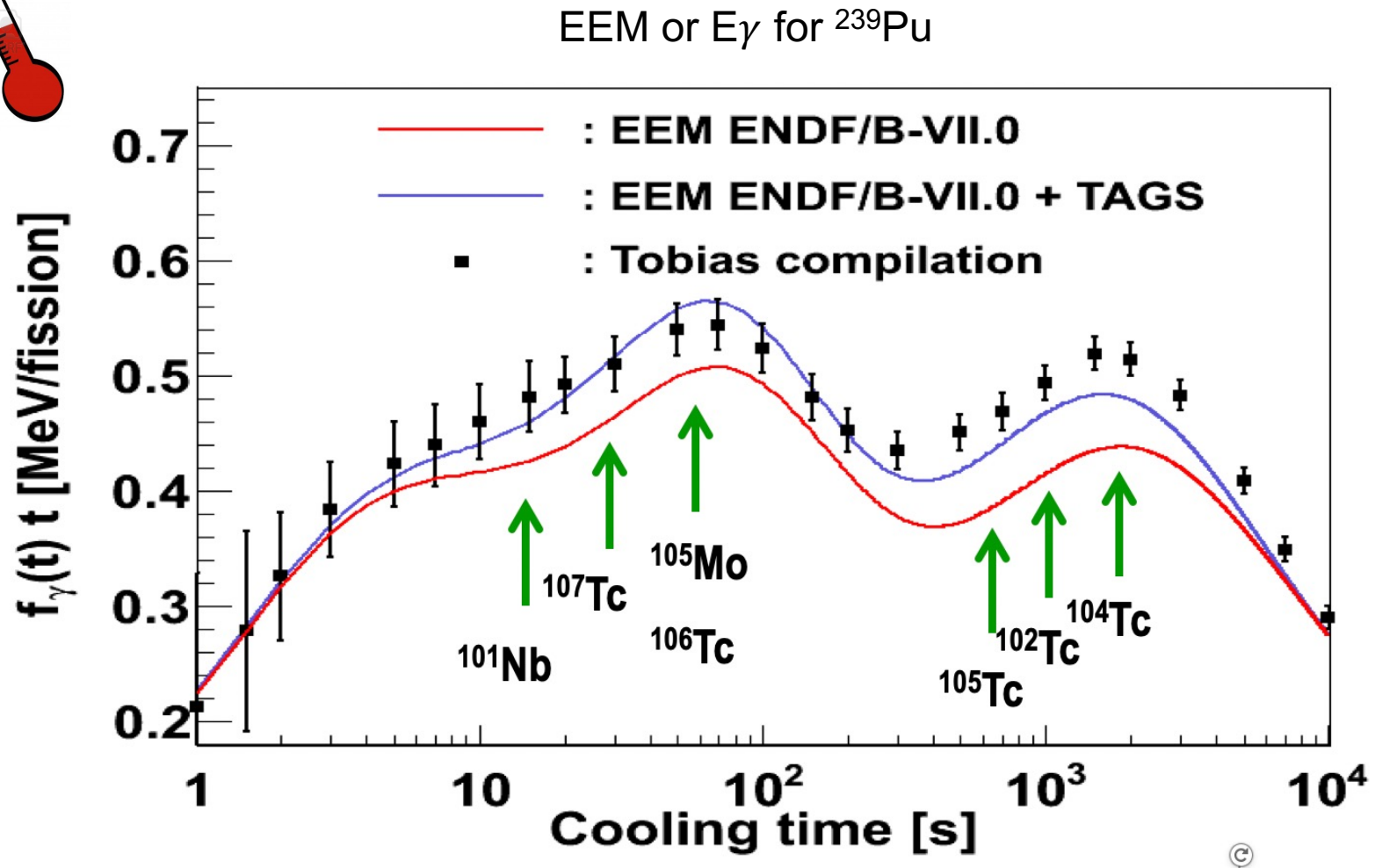

Dolores Jordan, PhD thesis

D. Jordan PRC 87, 044318 (2013)

Algora, Jordan, Tain et al., PRL 105, 202501, 2010

K. P. Rykaczewsky, Physics 3, 94 (2011)

Impact of some of our earlier data:

$^{102,104,105,106,107}\text{Tc}$, ^{101}Nb , ^{105}Mo

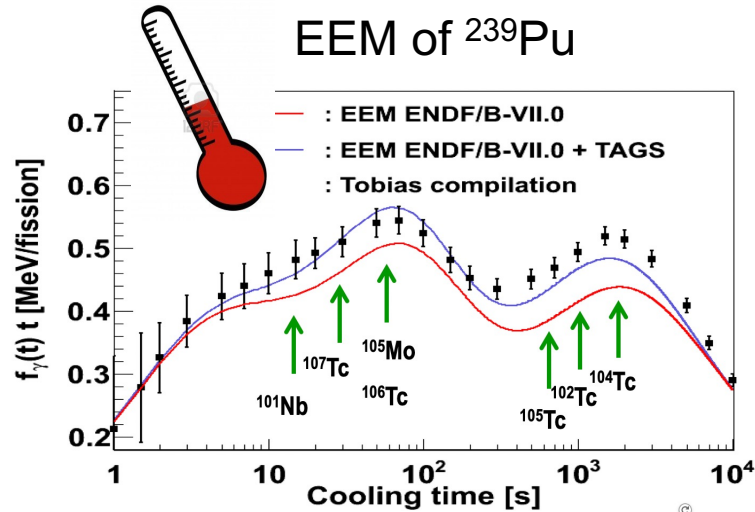

Dolores Jordan, PhD thesis
 D. Jordan PRC 87, 044318 (2013)
 Algora et al., PRL 105, 202501, 2010

M. Fallot et al., PRL 109.202504 (2012)

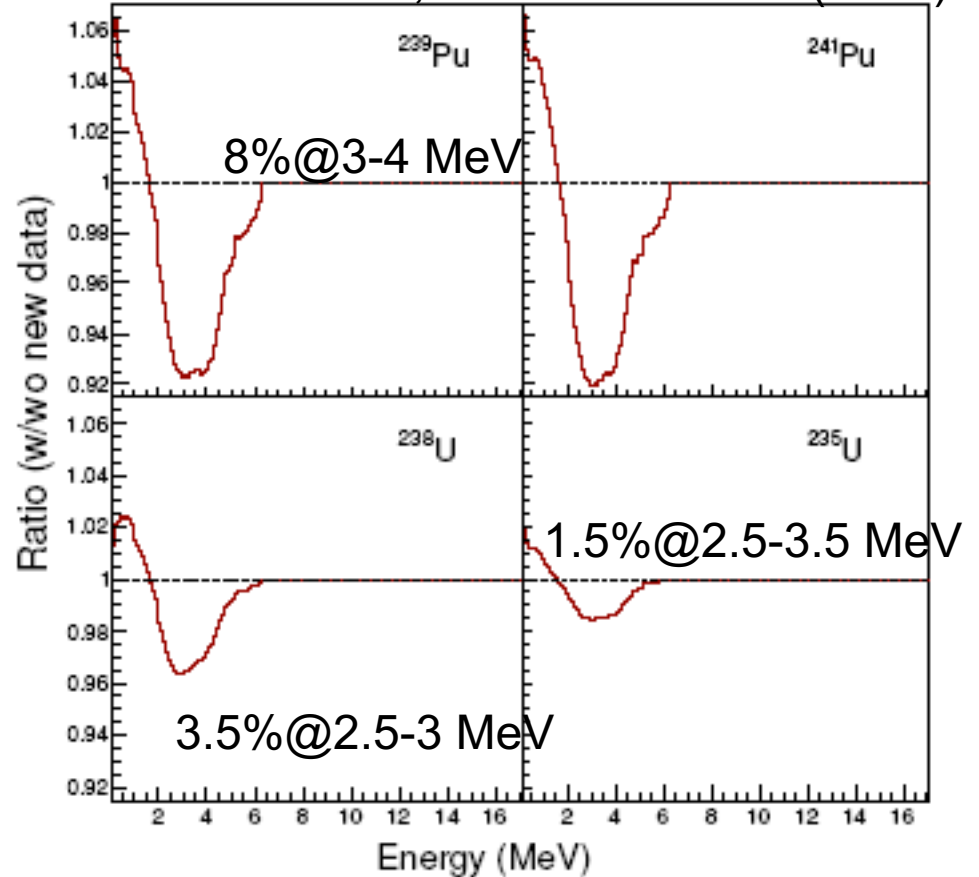

Ratio between 2 antineutrino spectra built with and without the $^{102,104,105,106,107}\text{Tc}$, ^{105}Mo , ^{101}Nb TAS data. Only 5 Pandemonium cases

Some published and on-going cases for Decay Heat and Antineutrino Spectrum calculations

Tables extracted from « Beta-decay studies for applied and basic nuclear physics », Algora et al. Eur. Phys. J. A 57 (2021) 85, 2020

Table 2. List of parent nuclides identified by the WPEC-25 (Nuclear Energy Agency working group) that should be measured using the total absorption technique to improve the predictions of the decay heat in reactors [48,49]. These nuclides are of relevance for conventional reactors based on ^{235}U and ^{239}Pu fission. The list contains 37 nuclides. Rel. (relevance) stands for the priority of the measurement. Isotopes marked with asterisks show the measurements performed by our collaboration. Nuclides marked with † are also relevant for the $^{233}\text{U}/^{232}\text{Th}$ fuel, see additional cases in Table 3. The isotopes are identified according to the Z-Symbol-A notation; m stands for metastable or isomeric state.

Isotope	Rel.	Isotope	Rel.	Isotope	Rel.
35-Br-86†*	1	41-Nb-99†	1	52-Te-135†	2
35-Br-87†*	1	41-Nb-100†*	1	53-I-136†	1
35-Br-88†*	1	41-Nb-101†*	1	53-I-136m†	1
36-Kr-89†	1	41-Nb-102†*	2	53-I-137†*	1
36-Kr-90†	1	42-Mo-103†*	1	54-Xe-137†	1
37-Rb-90m	2	42-Mo-105*	1	54-Xe-139†	1
37-Rb-92†*	2	43-Tc-102†*	1	54-Xe-140†	1
38-Sr-89	2	43-Tc-103†*	1	55-Cs-142*	3
38-Sr-97	2	43-Tc-104†*	1	56-Ba-145	2
39-Y-96†	2	43-Tc-105*	1	57-La-143	2
40-Zr-99†	3	43-Tc-106*	1	57-La-145	2
40-Zr-100†	2	43-Tc-107*	2		
41-Nb-98†*	1	51-Sb-132†	1		

Table 6. List of nuclides identified by the IAEA TAGS Consultants that should be measured using the total absorption technique to improve the predictions of the reactor antineutrino spectra. These nuclides are of relevance for conventional reactors based on ^{235}U and ^{239}Pu nuclear fuels. The list contains 34 nuclides [103]. Relevance (Rel.) stands for the priority of the measurement. Isotopes marked with asterisks show the measurements performed by our collaboration, m stands for metastable or isomeric state.

Isotope	Rel.	Isotope	Rel.	Isotope	Rel.
36-Kr-91	2	39-Y-97m	1	53-I-138*	2
37-Rb-88	1	39-Y-98m	1	54-Xe-139	1
37-Rb-90	1	39-Y-99*	1	54-Xe-141	2
37-Rb-92*	1	40-Zr-101	1	55-Cs-139	1
37-Rb-93*	1	41-Nb-98*	1	55-Cs-140*	1
37-Rb-94*	2	41-Nb-100*	1	55-Cs-141	2
38-Sr-95*	1	41-Nb-101*	1	55-Cs-142*	1
38-Sr-96	1	41-Nb-102*	1	57-La-146	2
38-Sr-97	2	41-Nb-104m	2		
39-Y-94	1	52-Te-135	1		
39-Y-95*	1	53-I-136	2		
39-Y-96*	1	53-I-136m	1		
39-Y-97	2	53-I-137*	1		

'Relatively recent' example: the challenging $^{100,102}\text{Nb}$ beta decay cases

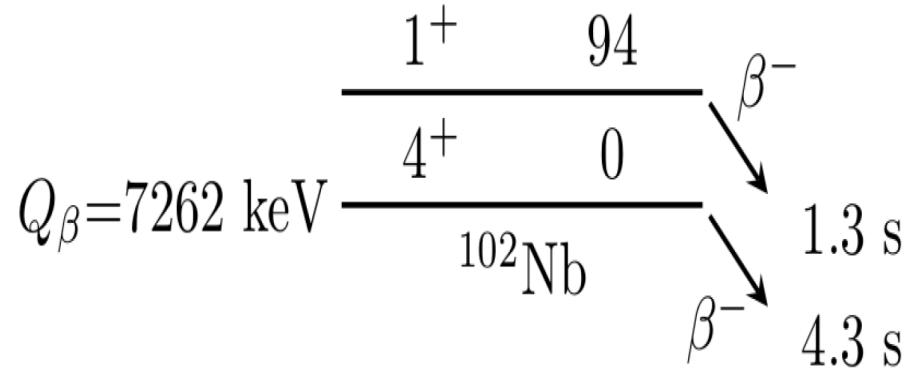
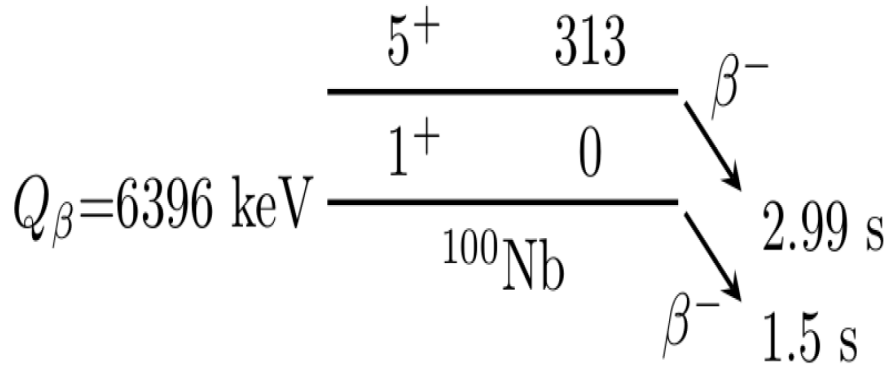
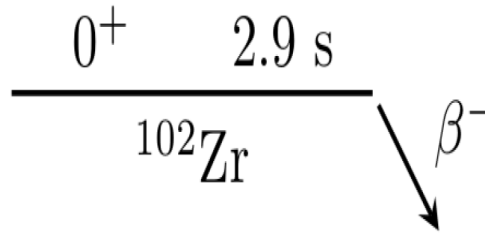
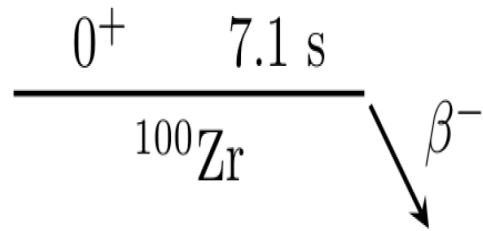

CFY of the order of 5%
and ~1 % respectively
(for both ^{235}U and ^{239}Pu)

Relevance in relation to Isomeric Yield Ratios,
see Sears et al., see talks by Mattera et al.

$^{102g_s}\text{Nb}$ decay (4+ state)

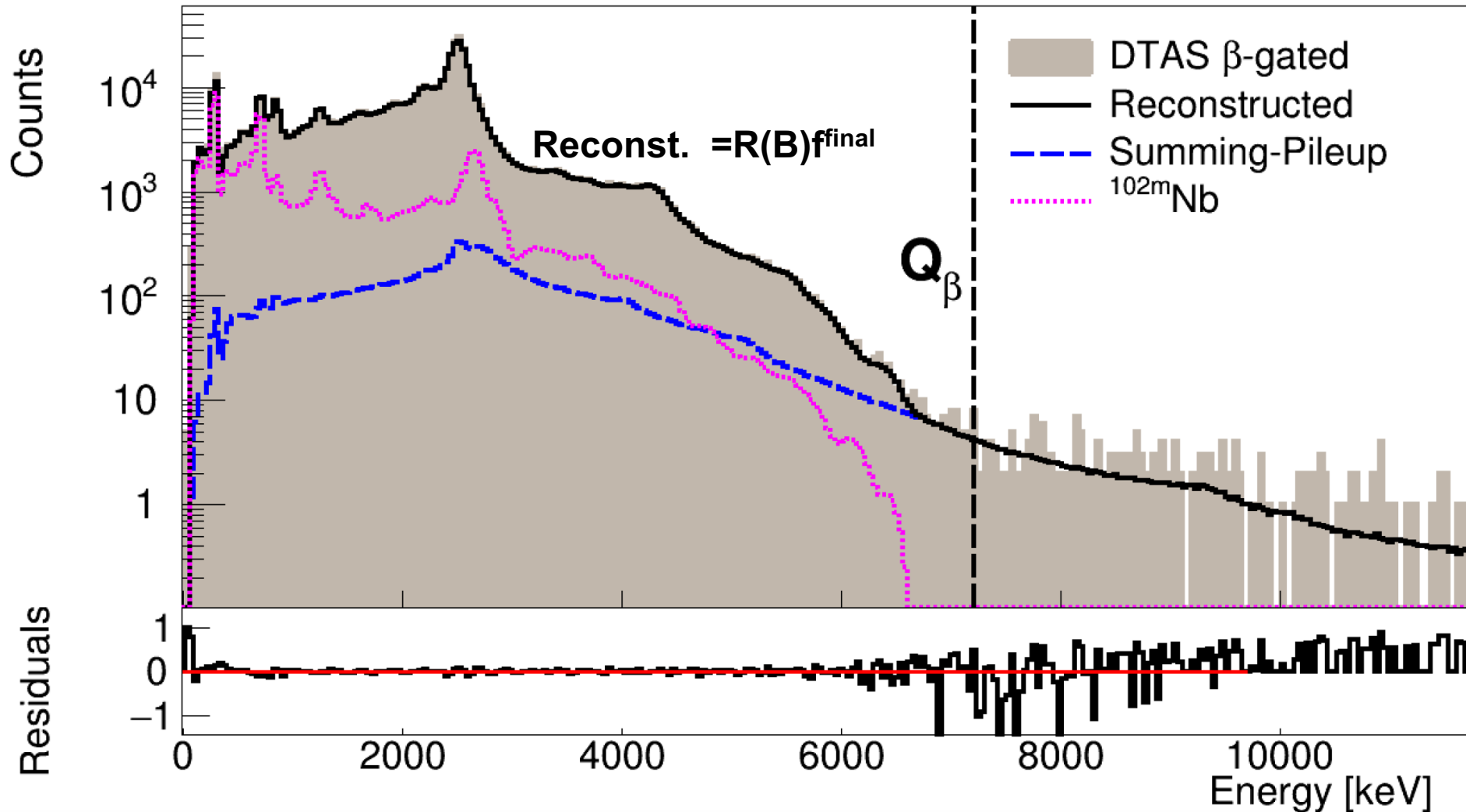
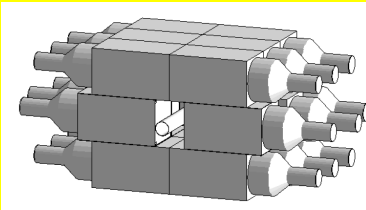

$^{102}\text{g.s. Nb}$ decay (4+ state)

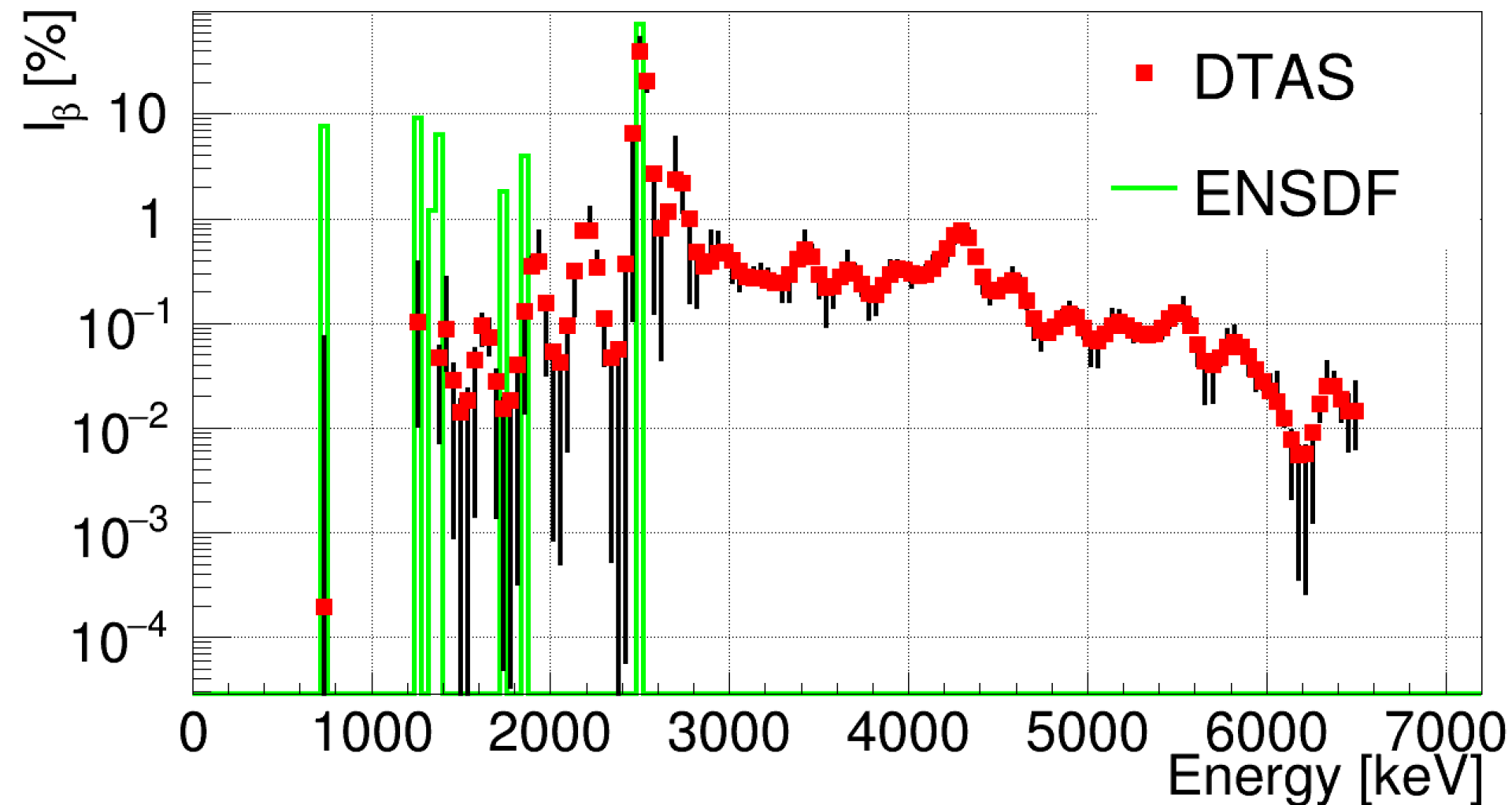
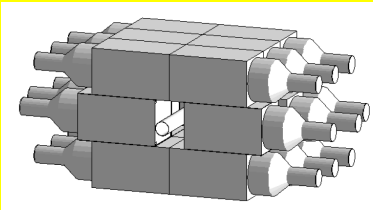

^{102m}Nb decay (1^+ state, 94 keV)

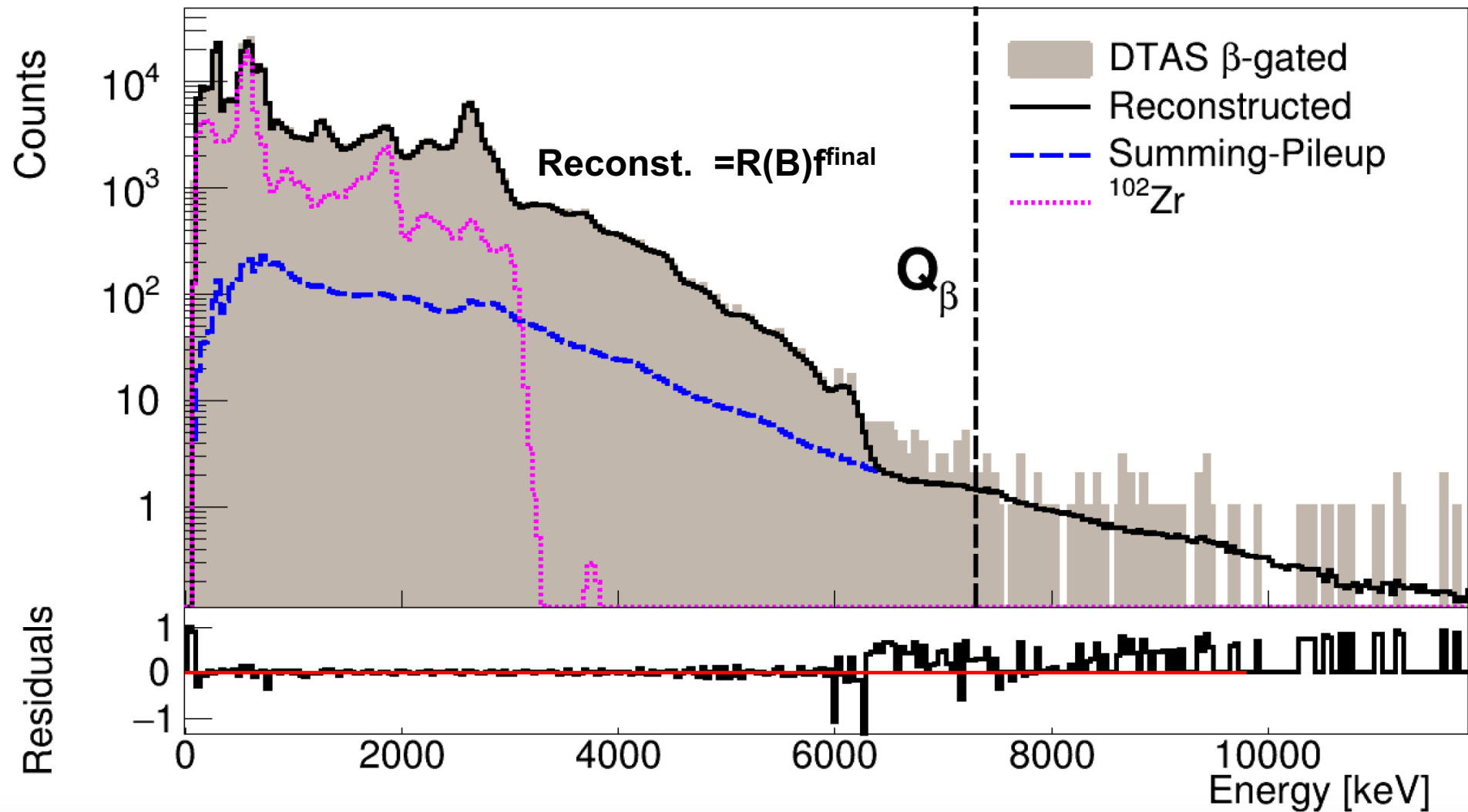
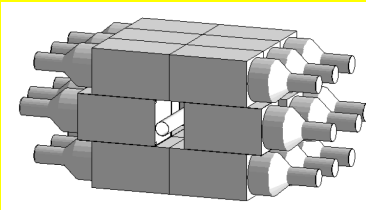

^{102m}Nb decay (1+ state, 94 keV)

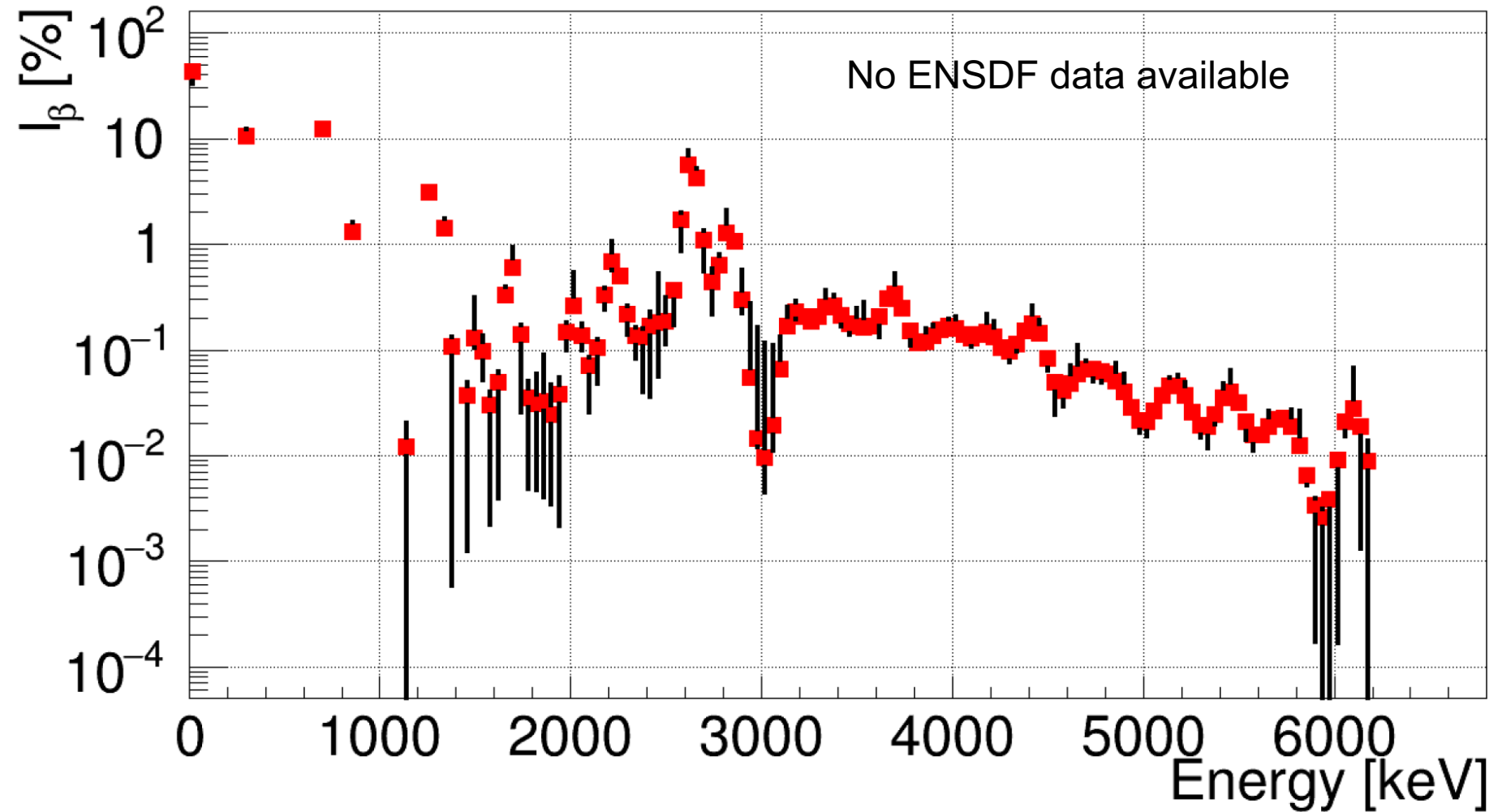
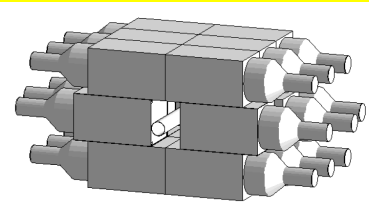

Decay heat impact of the measurements

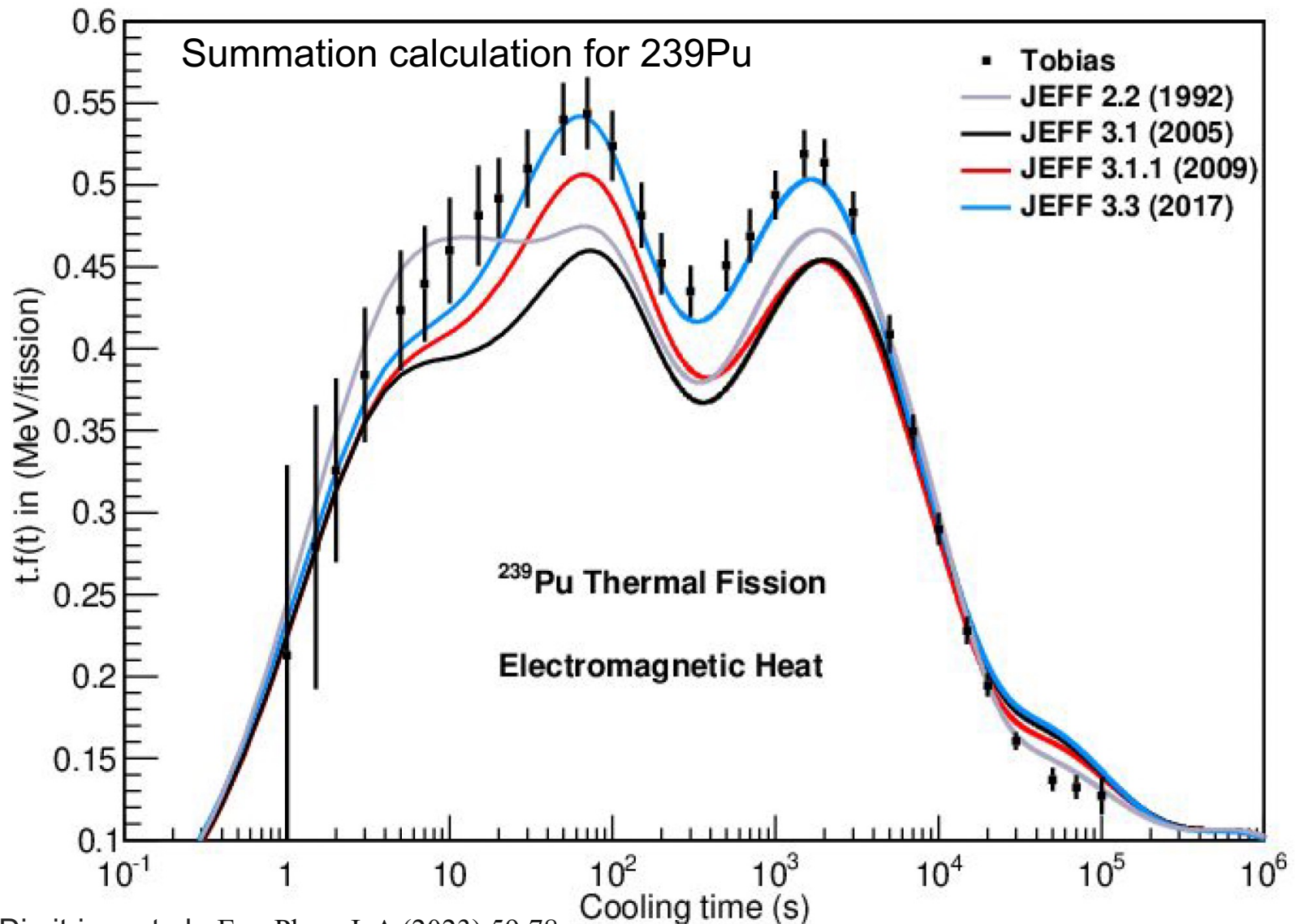

Antineutrino summation calc., reactor anomaly?

Results from the application of a new summation calculation including all our TAS measurements. The discrepancy with the antineutrino meas. within this model is of the order of 2 % questioning the existence of the anomaly itself.

M. Estienne, M. Fallot, et al. PRL 123, 022502 (2019)

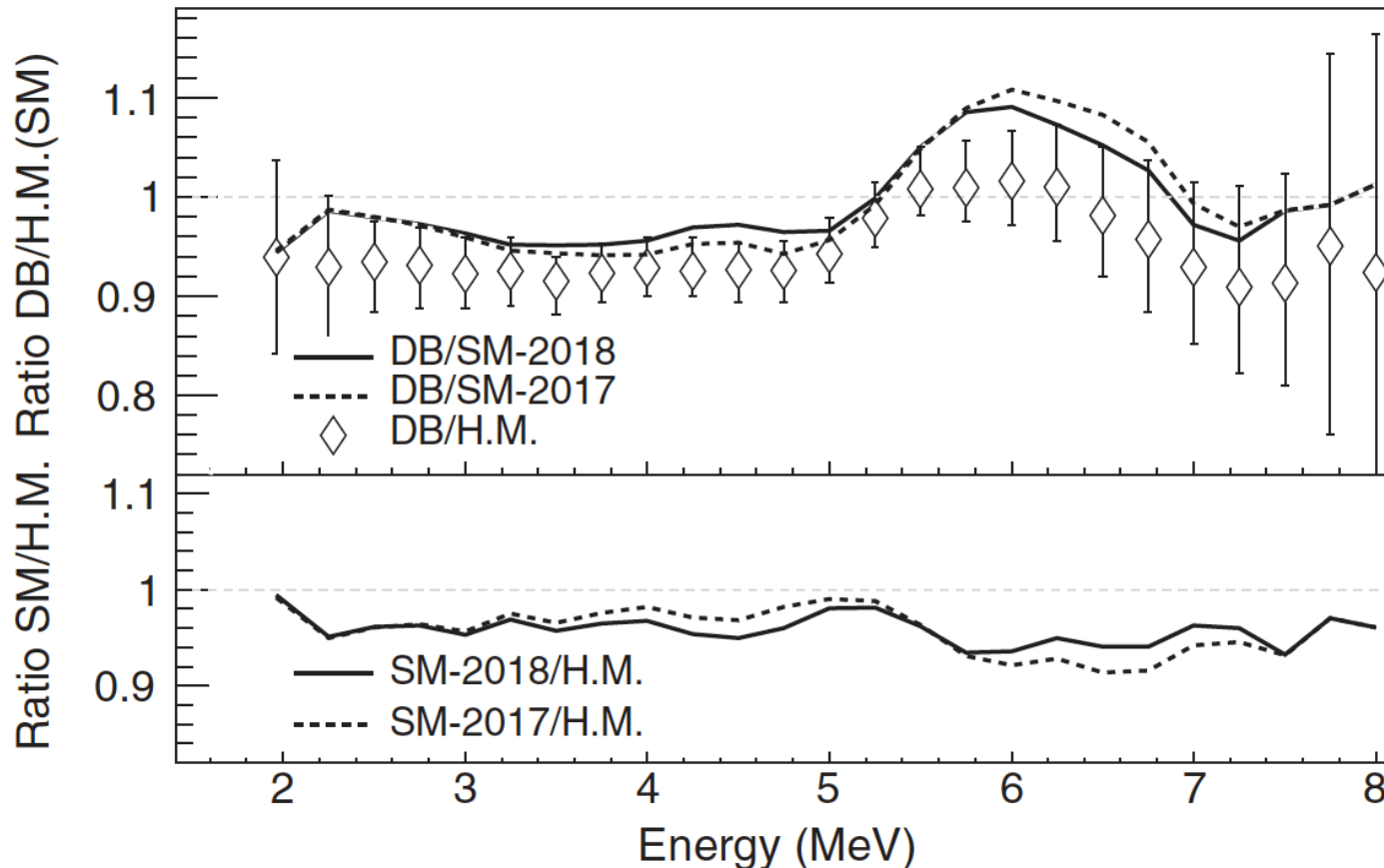

Subatech
Calculations
Estienne, Fallot,
et al.

Summation is
slightly better
than the Hueber-
Mueller
conversion
in the 2-5 MeV
range,

An alternative explanation: the spectrum shape

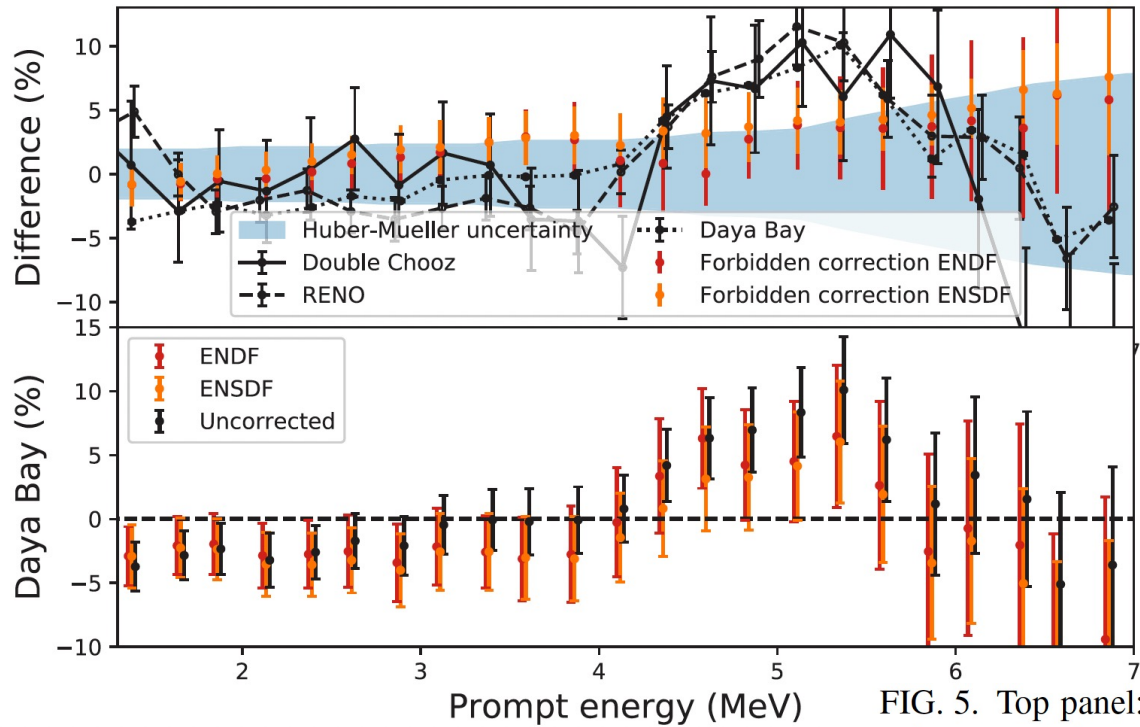

FIG. 5. Top panel: Normalized spectral ratios for three modern experiments relative to the Huber-Mueller predictions [2], and the normalized forbidden spectrum correction described in this work using ENDF and ENSDF decay libraries. The prompt energy of the positron emerging from the inverse β decay is related to the antineutrino energy via $E_{\text{prompt}} \approx E_{\nu} - 0.782$ MeV. Bottom panel: Difference between Daya Bay spectral data and different theoretical models. Error bars are calculated using experimental, H-M, and forbidden uncertainties and are assumed uncorrelated. Here Uncorrected is relative to the H-M estimate shown in the top panel, and ENDF and ENSDF are the new results.

$$\frac{dN}{dW} = pW(W - W_0)^2 F(Z, W) C(Z, W) K(Z, W),$$

$$C_{0^-} = 1 + \frac{2R}{3W} b + \mathcal{O}(\alpha Z R, W_0 R^2),$$

$$C_{1^-} = 1 + aW + \mu_1 \gamma \frac{b}{W} + cW^2,$$

Need for beta shape measurements: not new

Earlier attempts:

Tengblad, Rudstam, et al.

Nucl. Phys. A503 (1989) 136; Atomic Data and Nuclear and Data Tables 45 (1990)239

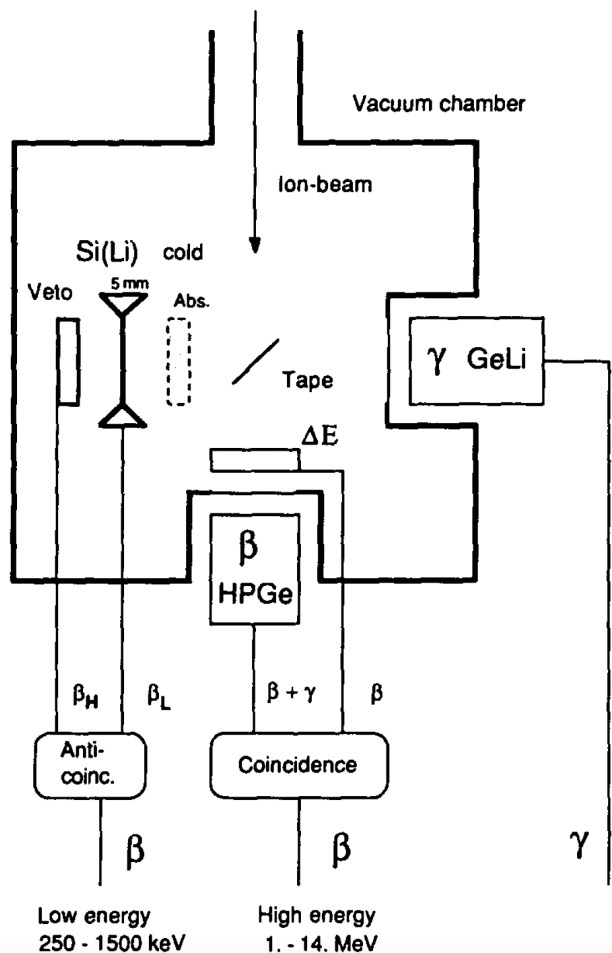

The continuous spectra was considered important for testing beta decay data consistency and for determining mean beta (and gamma energies with other setup) released in beta decays for decay heat and for antineutrino summation calculations.

Measurements performed at Osiris (Studsvik) and CERN-ISOLDE

In principle these measurements are free from the problems that can have deduced spectra from gamma spectroscopy measurements (assumptions about the shape)

Issues: comparison with TAS results

The direct beta spectrum measurements can be compared with the beta spectrum deduced from the beta feedings of the TAGS measurements

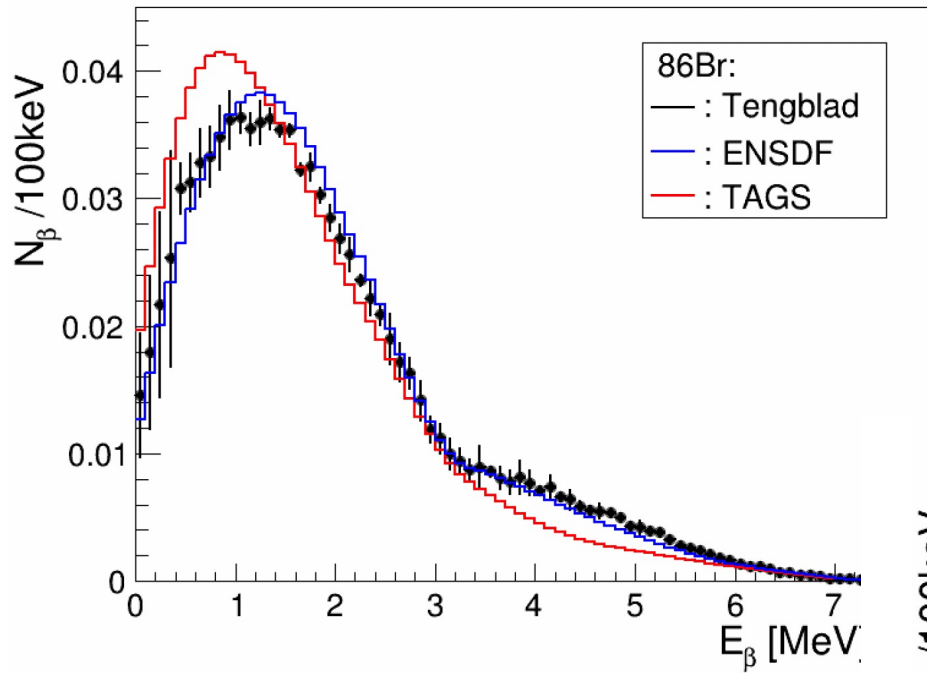

Unfortunately, not the only cases

VERY UPSETTING

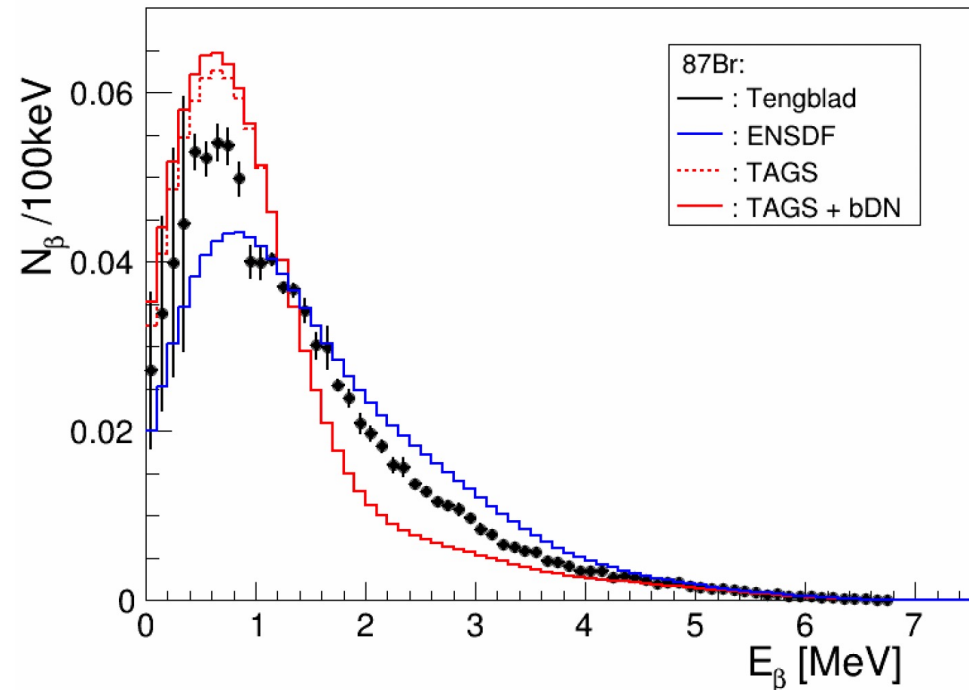

Out of the confort zone: Measurements of the shape of the beta spectrum

I206, I233, I233Add IGISOL proposals, Univ. of Jyväskylä

Spokespersons: A. Algora, M. Fallot, W. Gelletly, local contact: Tommi Eronen

Objetive: measure the shape of the beta spectrum of the most relevant fission products using isotopically pure beams (trap assisted spectroscopy)

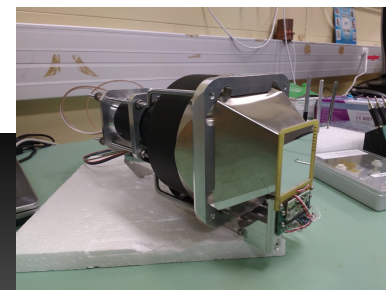
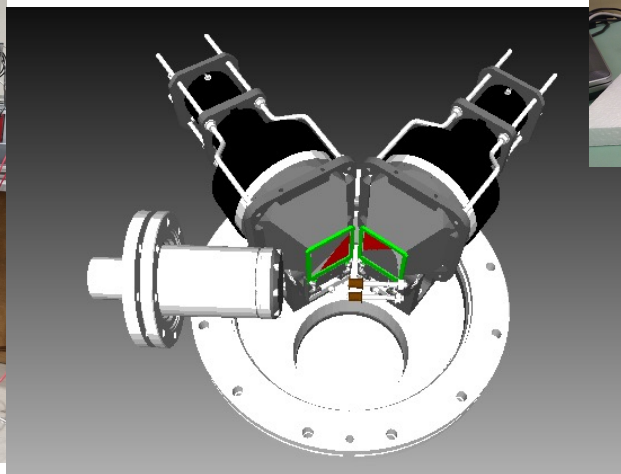
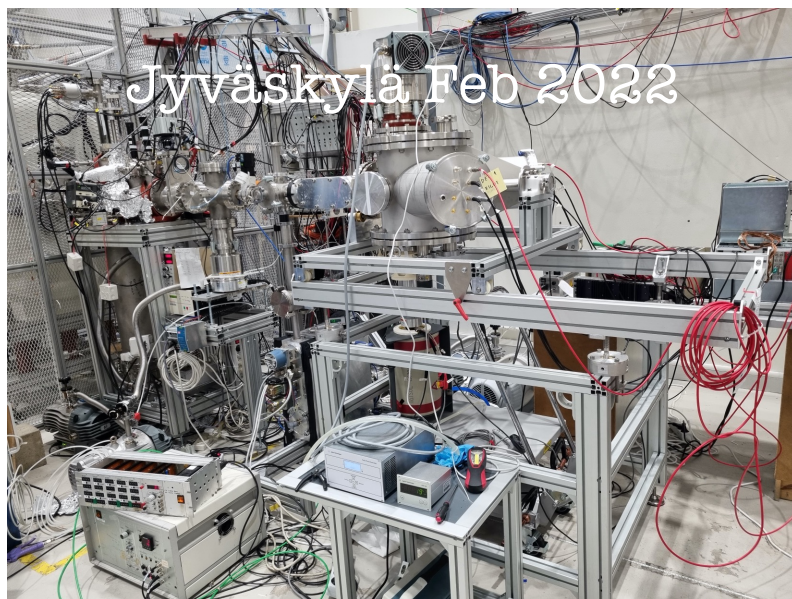

Several works and publications emphasize the need of such measurements:

Hayes et al. PRL 112.202501 (2014)

Sonzogni et al. , PRL 119.112501 (2017)

Hayen et al. PRC 99.031311 (2019)

Technical Meeting (IAEA, 2019), Report INDC-NDS-0786

We made the front page of the annual report

Setup (Valencia-Nantes-Surrey-Warsaw):

EJ200 plastic (Scionix),

507 um Si detectors (Micron)

Custom modified CAEN preamplifiers

See details in Guadilla et al., JINST 19

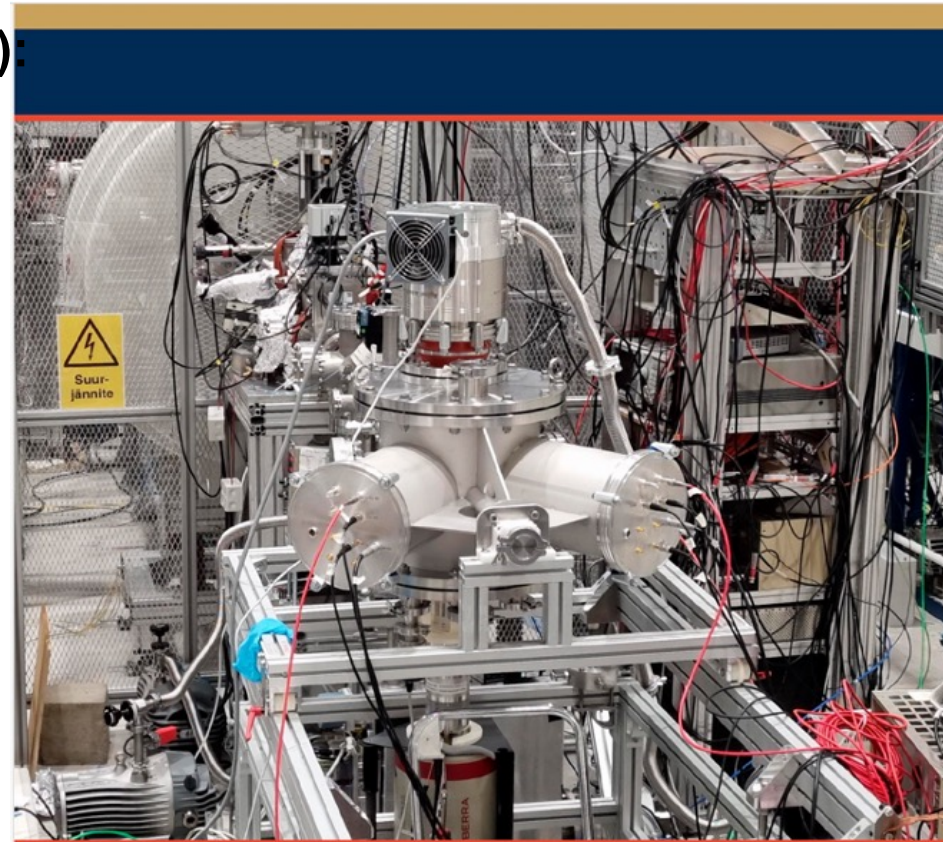
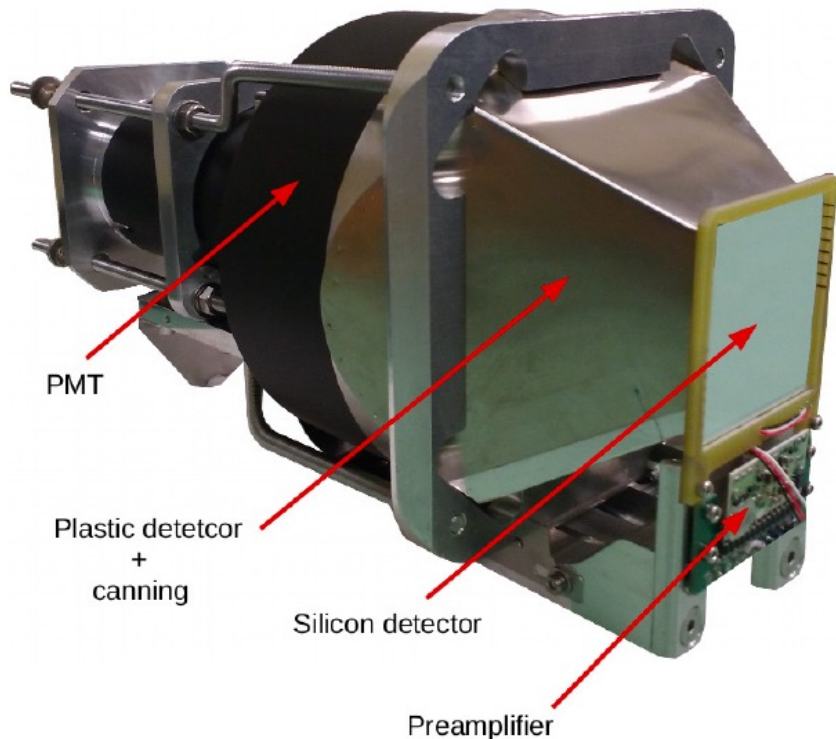

How these challenging experiments are analyzed?

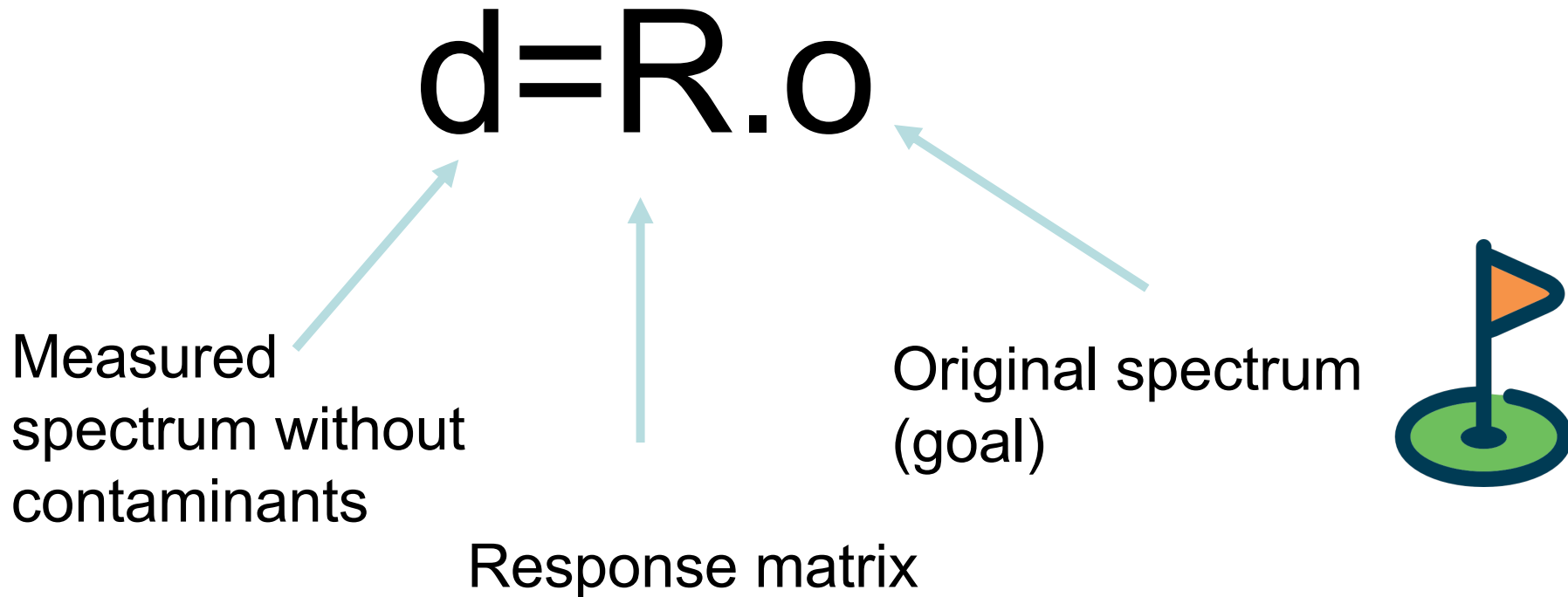

Needs/challenges:

Excellent calibration (energy and width)

Well controlled Monte Carlo simulations

Methods for solving the inverse problem

Monte Carlo model of the e-shape setup

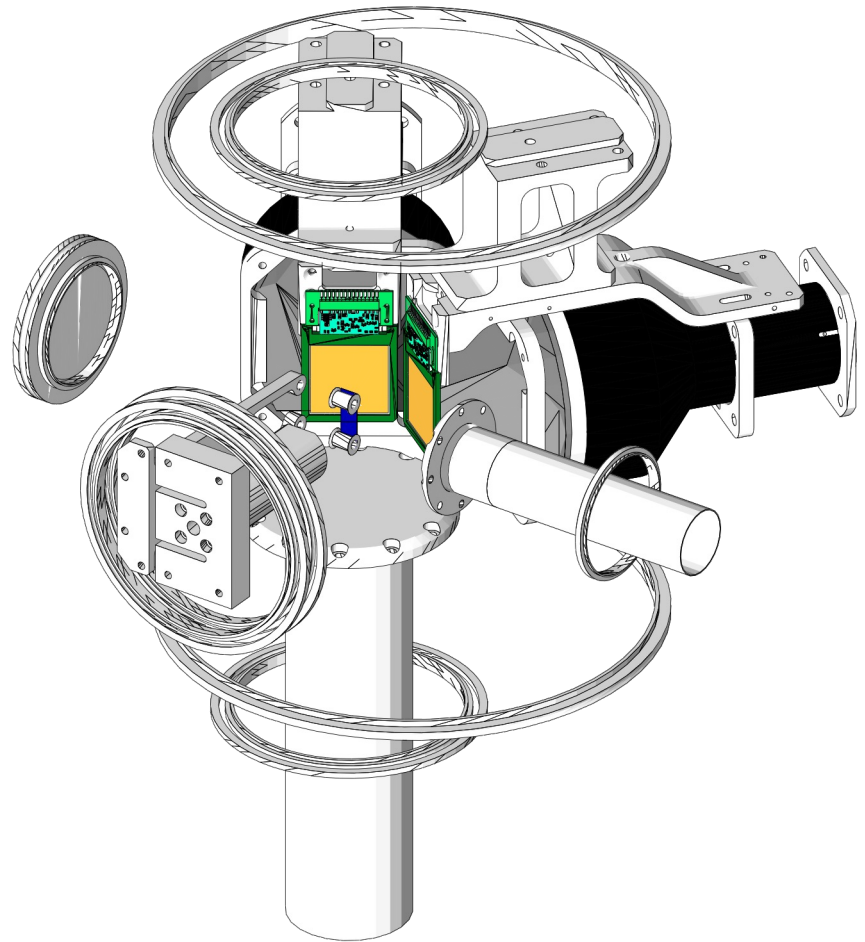
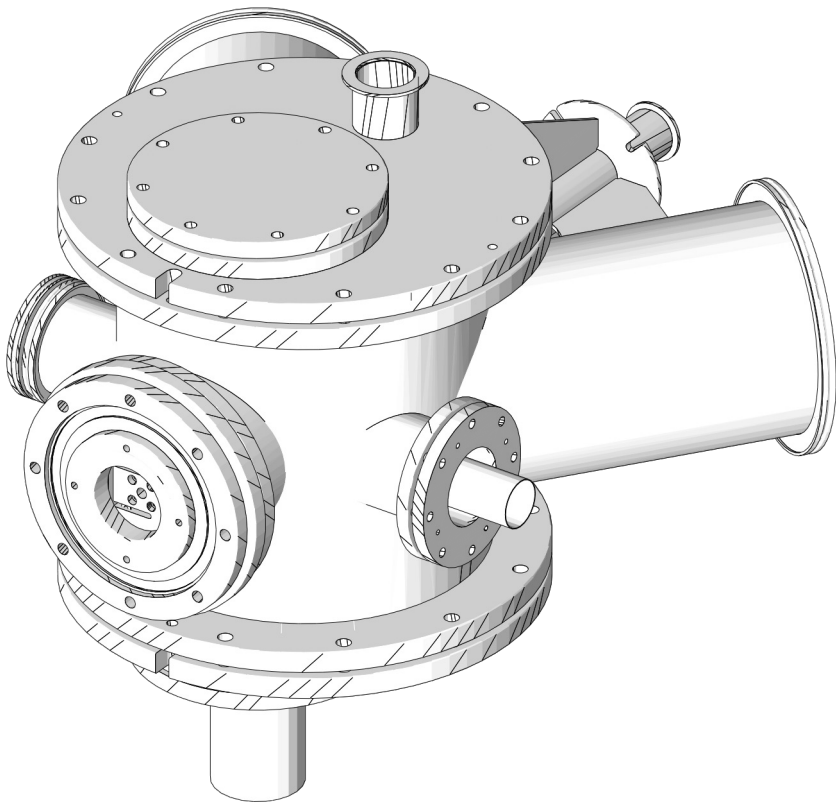

Geant4 version 10.5.1, Livermore Physics (Penelope, was also tested)

Validation of MC: 114Pd-114ag decay

Pd-114 - Plst1Coin - I233 Sim. Vs Exp. - Binning = 100 keV

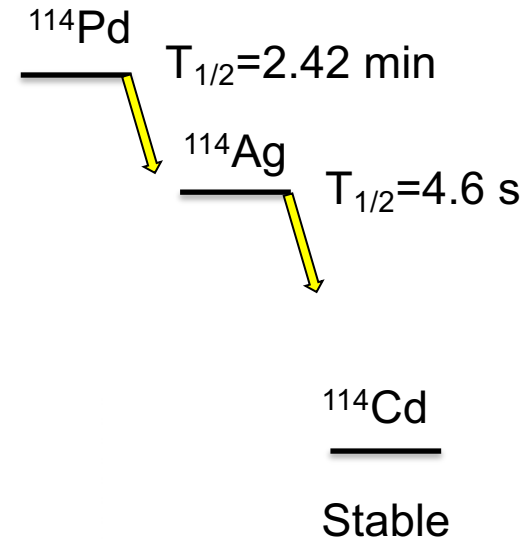
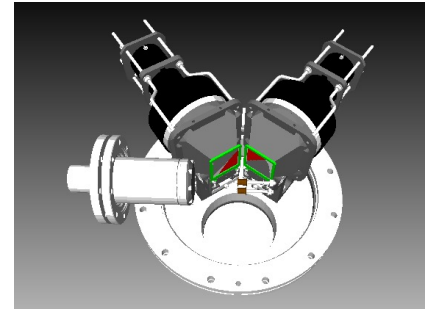
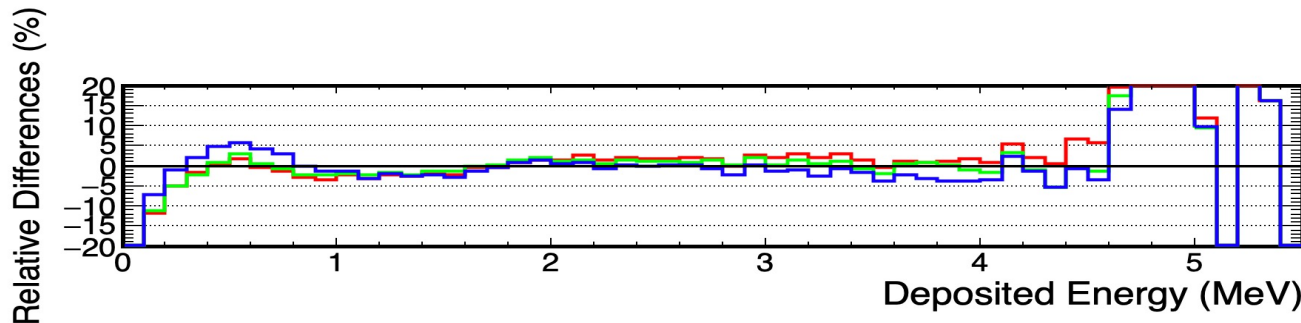
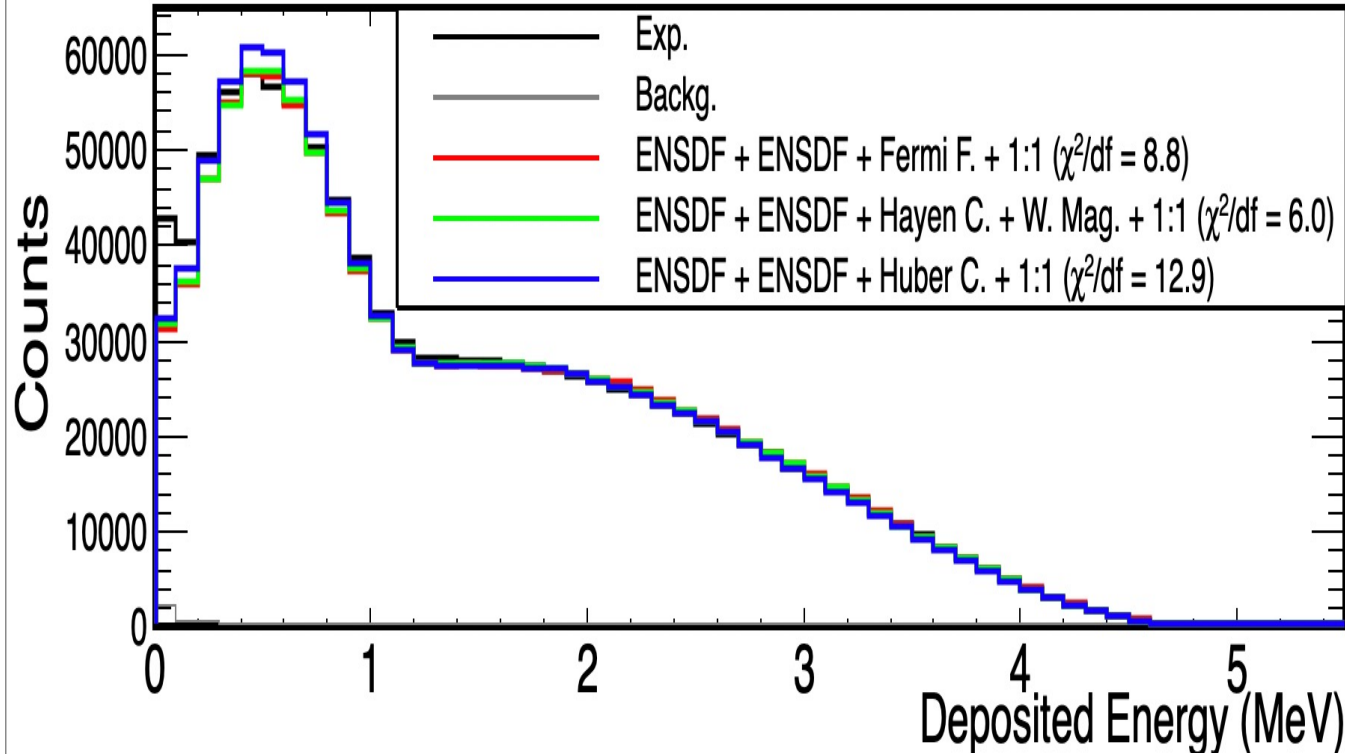

Note: ENSDF
 Calibrations: beta
 endpoints, E0 98Mo

Matrix response calculation: analysis in coinc. mode

$$d=R.o$$

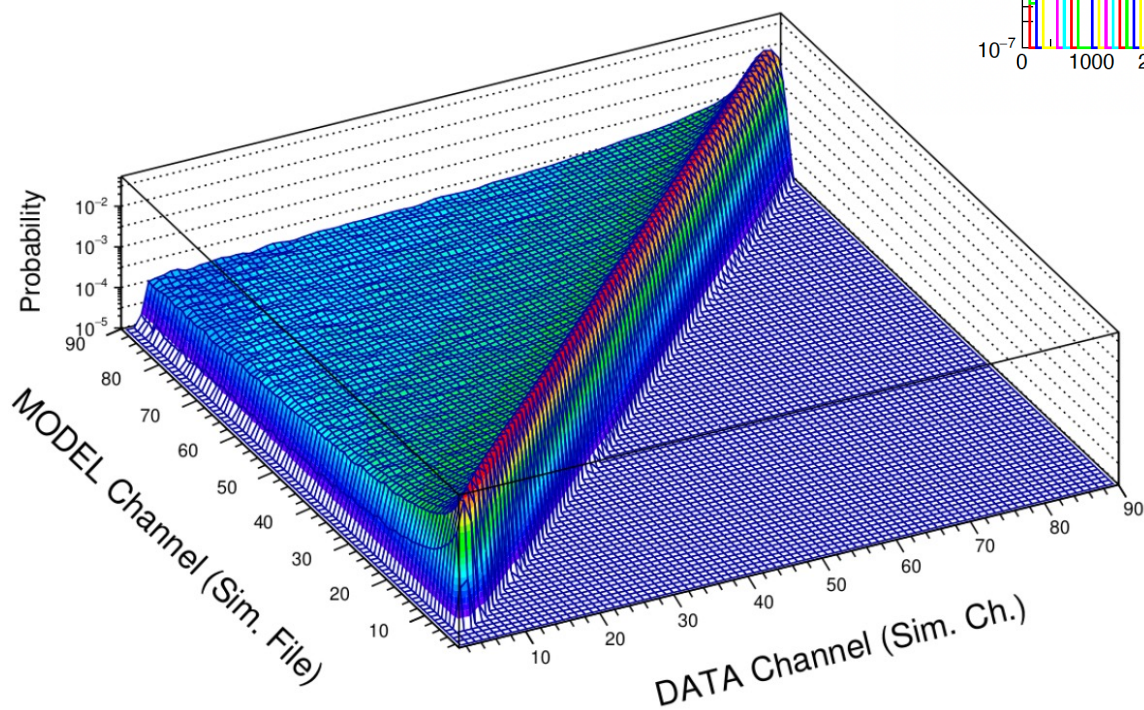
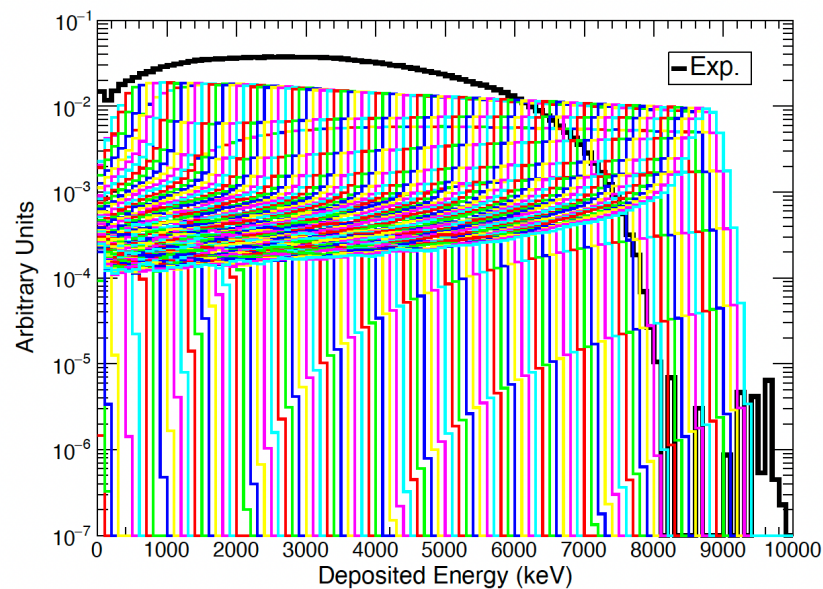

Analysis of ^{92}Rb

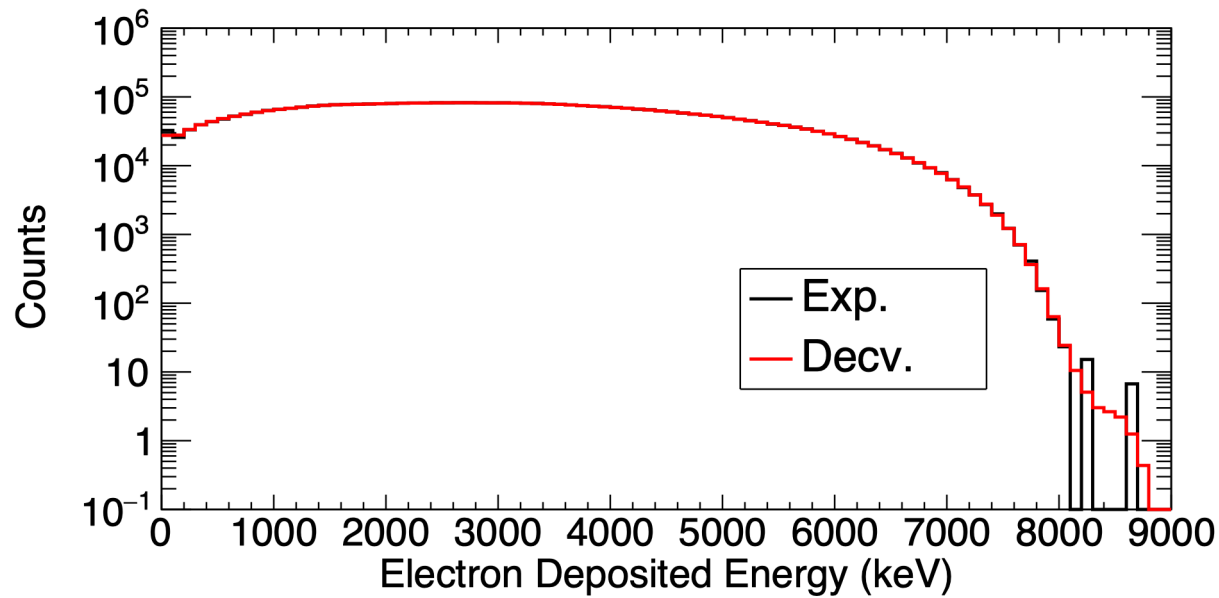

Exp (d) vs R.o_final

Contaminations subtracted:
pileup, daughter activity, etc.

Expectation-Maximization
algorithm
(see Tain, Cano NIMA)

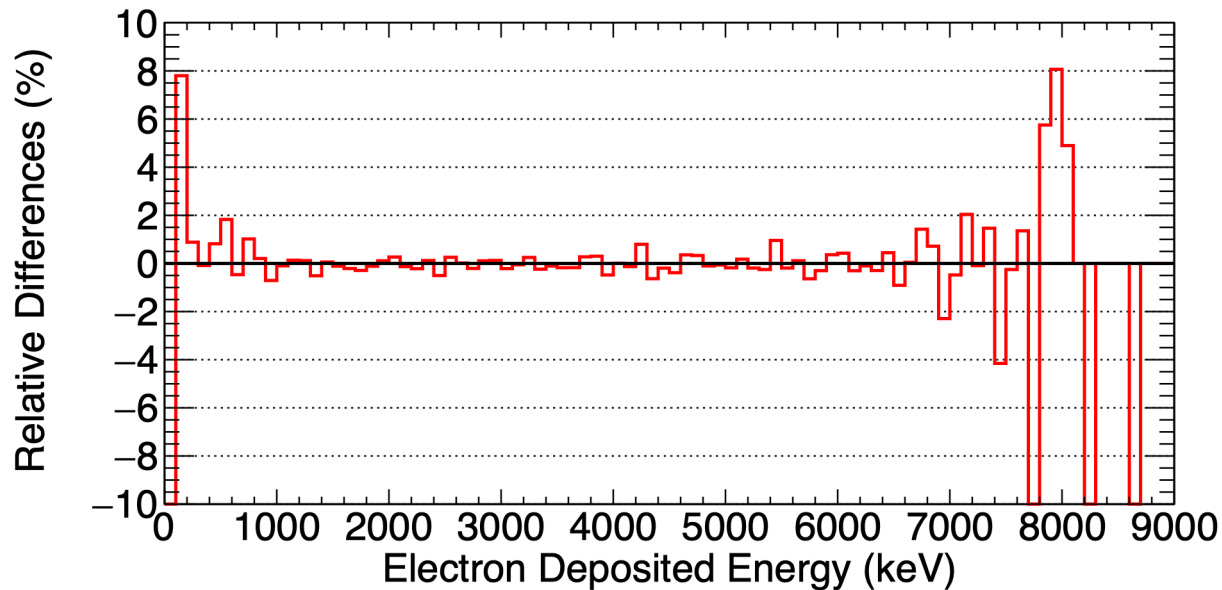

Deduced beta spectrum of the beta decay of ^{92}Rb

Alcalá et al, PRL 135, 142502 (2025)

Deduced ^{92}Rb beta spectrum compared with model predictions

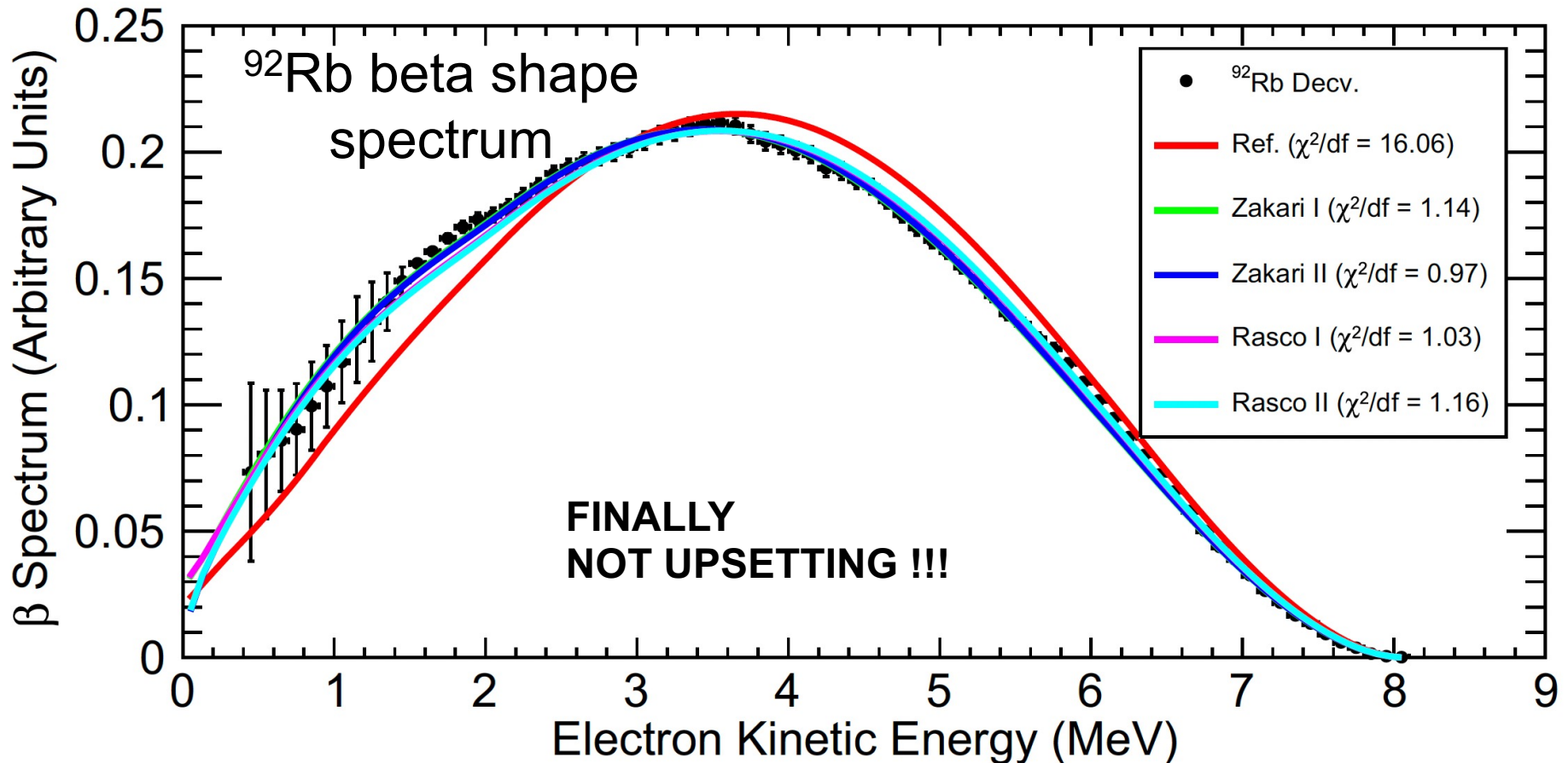

Test of the corrections applied for this important case for neutrino physics. Validation of the smallness of the correction for FF $0^- \rightarrow 0^+$ decays. Remember that ^{92}Rb is the most relevant decay of all (its contribution amounts to 16% of the in 5-8 MeV range).

G. Alcalá, PhD thesis, Valencia

Comparison with Tengblad data

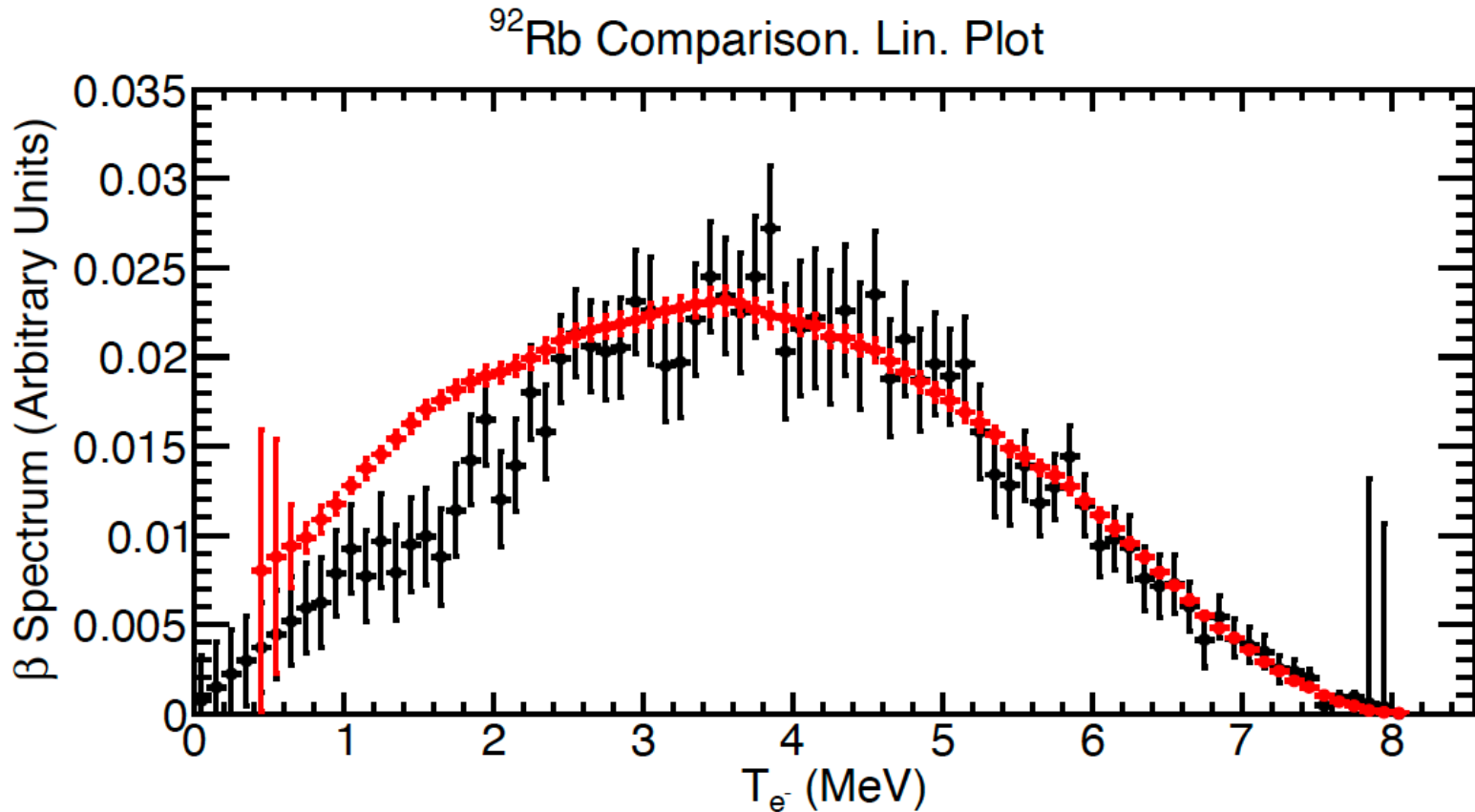

Remember that ^{92}Rb is the most relevant decay of all (its contribution amounts to 16% of the in 5-8 MeV range)

Message



- I hope that I have shown that the TAGS technique and beta shape measurements can contribute to the improvement of nuclear data for reactor applications, in particular for (DH and antineutrino) summation calculations.
- Our results come from careful measurements and analyses. Special care have been devoted to the purity of the beams (trap assisted spectroscopy) and to the characterization of the detectors. There has been a continuous development of analysis techniques. New research line, beta shape measurements.
- There are still several cases measured to be published from the top contributors to the neutrino spectrum, other groups are also working on the topic (Oak Ridge-Warsaw group)

Thank you

Thanks are due to my colleagues from Valencia, Nantes, Surrey, Warsaw, and Jyväskylä, without them this work could have not been possible

TAS project main contributors (students first): J. Pepin, V. Guadilla, L. Le Meur, Z. Issoufou, S. Rice, E. Valencia, M. D. Jordan, J. L. Tain, M. Fallot, M. Estienne, J. Agramunt, A. Porta, J. A. Briz, A. A. Sonzogni, T. Eronen, et al...., A. Algora

Shape project main contributors: G. Alcala, M. Fallot, M. Estienne, V. Guadilla, S. Bouvier, W. Gelletly, J.S. Stuzmann, A. Porta, et al....., A. Algora

Support from the ASFAE, SANDA, APRENDE, Prometeo, etc. projects are acknowledged.